

Czech Technical University Prague

Faculty of Electrical Engineering

Specialization in Electrical Machine Apparatuses and Drives

Department of Electric Drives and Traction



Diploma Thesis

**Survey about Current State of The Art of Electromobiles and Future
Development Trends**

Shubhang Maheshkumar Vyas

Acknowledgement

I would like to thank Guide: Ing. Jan Bauer, Ph.D.

© 2019 CTU Prague



MASTER'S THESIS ASSIGNMENT

I. Personal and study details

Student's name: **Vyas Shubhang** Personal ID number: **464352**
Faculty / Institute: **Faculty of Electrical Engineering**
Department / Institute: **Department of Electric Drives and Traction**
Study program: **Electrical Engineering, Power Engineering and Management**
Branch of study: **Electrical Machines, Apparatus and Drives**

II. Master's thesis details

Master's thesis title in English:

Survey about Current State of Art of Electromobiles and Future Development Trends

Master's thesis title in Czech:

Survey about Current State of Art of Electromobiles and Future Development Trends

Guidelines:

- 1) Make a survey about electromobiles manufactured in world (type of machines, type of batteries, price, range on one battery)
- 2) Make a survey about batteries (types, volume, weigh, energy, charging cycles)
- 3) Make a survey about charging stations in europe (voltage, power, connector, communications)
- 4) Make a survey about future trends in electromobility
- 5) Based on the collected materials compare pure electromobile with hybrid car from the possible use poin of view

Bibliography / sources:

- [1] Internet
- [2] Manufacturers data
- [3] <https://survey.pluginamerica.org/model-3/battery-packs.php>
- [4] https://batteryuniversity.com/learn/archive/whats_the_best_battery

Name and workplace of master's thesis supervisor:

Ing. Jan Bauer, Ph.D., Department of Electric Drives and Traction, FEE

Name and workplace of second master's thesis supervisor or consultant:

Date of master's thesis assignment: **26.09.2018** Deadline for master's thesis submission: **24.05.2019**

Assignment valid until: **19.02.2020**

Ing. Jan Bauer, Ph.D.
Supervisor's signature

Head of department's signature

prof. Ing. Pavel Ripka, CSc.
Dean's signature

III. Assignment receipt

The student acknowledges that the master's thesis is an individual work. The student must produce his thesis without the assistance of others, with the exception of provided consultations. Within the master's thesis, the author must state the names of consultants and include a list of references.

Date of assignment receipt

Student's signature



Declaration

I declare that I have worked on my diploma thesis titled "Survey about Current State of The Art of Electromobiles and Future Development Trends " by myself and I have used only the sources mentioned at the end of the thesis. As the author of the diploma thesis, I declare that the thesis does not break copyrights of any of the persons.

In Prague on,

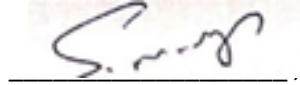
A handwritten signature in black ink, appearing to be 'S. ...', is written on a light-colored rectangular background. Below the signature is a horizontal line.

Signature

Acknowledgement

First and Foremost, I would like to express my sincere gratitude to my supervisor Doc. Ing. Jan Bauer, PhD, the head of the Department Of Electric Drive And Traction from faculty of electrical engineering at Czech Technical University for his motivation, enthusiasm and deep knowledge. He helped me to introduce the topic as well as support during the learning process of this master thesis. I could not have imagined having a better advisor and mentor of my thesis. I would like to thank my friends and colleagues for their moral support.

And last but not least, I would really like to thank a lot to my Parents for their encouragement and support.

ABSTRACT

In the beginning of this Thesis I made a survey about Electric Cars (Electromobiles) from globally renowned manufacturers. Then, the next step was to look into more technical aspects of the Vital Components of an Electromobile namely Batteries and Drive Train. Because of the fact that Battery Pack holds the central role in performance and also costing of an Electromobile, I have treated Battery section with Highest Resolution. This section also briefly goes into Engineering of Manufacturing Battery Packs and Electro-chemical & Economical studies of the materials that are used in the Battery Chemistry and Construction. Along with studies of Battery Technology, it is highly recommendable to study Existing Charging Technologies for Electromobiles in Europe and to look into problems of charging facility infrastructure throughout Europe and then at the world level. Later in this section I have reflected the impact of this problem on customer and on the popularity of Electromobiles and also remedies that can be implemented to increase the level of harmony in charging infrastructure of Electromobiles to improve market conditions. In the further part I have developed Performance Analysis which is in its core sense a Mathematically Simulated Reality in Microsoft Excel Environment where I have selected 3 different Electric Car Models to find out validity of the statistical performance claims made by their manufacturers. The key specifications under the check are Energy Consumption and Range of a car. This approach involves dynamics analysis of cars for two top speed variant 90 kmph and 120 kmph, under finite constant road conditions between CVUT in Prague as the point of departure and Technical University in Brno as the destination. Please study both the excel sheets named as "Performance Analysis" to learn more. Having studied all practiced technologies in detail the next step of this Thesis is to look into Future of Electromobile Technologies that again of course involves a brief study of new Innovations in Battery Technologies and other Electrical Improvements which are to be launched into mainstream market with some new car models by Year 2020 and onwards. Further as per the objective of the thesis I have developed technical comparison between the best of Electromobiles and equivalently comparable Hybrid Car in the main stream market. Then to finally justify comparison, I have developed a Mathematical Model of Economic Analysis of Electromobile and Hybrid Car with the goals of finding out the Cost of driving an Electric Car (Electromobile) as opposed to a Hybrid car and then of concluding the Payback Period of an Electric Car to compensate its Higher Capital Investment with respect to that of a Hybrid Car. This Economic Analysis can be found in the Excel file named "Czech Economic Analysis of EV and Hybrid" for Czech Market condition and for US Market conditions refer to the file named as "US Economic Analysis of EV and Hybrid".

These much is done to find out whether the Electromobiles hold Brighter Future Possibilities as opposed to Hybrid Cars or not, referring to major concerns of Technology, Economy and most importantly Ecology.

Keywords:

Electromobiles, Regenerative Breaking, v/f control, Intercalation, Statista, Bloomberg, BMS, CHAdeMO, CCS, Superchargers, Performance Analysis, Mathematically Simulated Reality, Dynamics Analysis, Pythagorean Depiction, Recuperation Efficiency, Driving Efficiency, Efficiency Based Energy Calculation, Dry Electrode Manufacturing Process, Graphene, Silicon Nano-Technology, Solid Electrolyte, LiSiCON, Solid State Batteries, Ultra Capacitors, Nano Flow Cell Technology, Fisker EMotion, Czech Economic Analysis of EV and Hybrids, Payback Period, NCEs, US Market, Ecology.

ABSTRAKT

Na začátku této práce jsem provedl průzkum o elektrických automobilech (elektromobilech) od světově uznávaných výrobců. Dalším krokem pak bylo zkoumat více technických aspektů vitálních komponent elektromobilu, jmenovitě baterií a hnacího ústrojí. Vzhledem k tomu, že Battery Pack má ústřední roli ve výkonu a také v nákladech na elektromobily, upravil jsem sekci Battery s nejvyšším rozlišením. Tato část se také stručně věnuje inženýrství výroby bateriových sad a elektrochemickým a ekonomickým studiím materiálů, které se používají v chemii a konstrukci baterií. Spolu se studiem technologie baterií je velmi vhodné studovat stávající nabíjecí technologie pro elektromobily v Evropě a zabývat se infrastrukturou nabíjecích zařízení v celé Evropě a poté na světové úrovni. Později v této části jsem zohlednil dopad tohoto problému na zákazníka a na popularitu Elektromobilů a také nápravná opatření, která mohou být implementována za účelem zvýšení harmonie v nabíjecí infrastruktuře Elektromobilů za účelem zlepšení tržních podmínek. V další části jsem vypracoval analýzu výkonu, což je v zásadě matematicky simulovaná realita v prostředí Microsoft Excel, kde jsem vybral 3 různé modely elektrických automobilů, abych zjistil platnost statistických údajů o výkonu předložených jejich výrobcí. Klíčové kontrolované specifikace jsou spotřeba energie a dojezd automobilu. Tento přístup zahrnuje dynamickou analýzu automobilů pro dvě varianty nejvyšší rychlosti 90 km/h a 120 km/h, za konečných konstantních silničních podmínek mezi ČVUT v Praze (jakožto začátkem cesty) a Technickou univerzitou v Brně (jakožto cílem cesty). Chcete-li se dozvědět více, prostudujte si oba excelové listy nazvané „Analýza výkonu“. Po podrobném prostudování všech praktických technologií je dalším krokem této práce rozbor budoucnosti elektromagnetických technologií, který opět samozřejmě zahrnuje krátkou studii nových inovací v bateriových technologiích a dalších elektrických vylepšeních, která mají být uvedena na hlavní trh s novým vozem modely do roku 2020 a dále. Dále jsem v souladu s cílem bakalářské práce vypracoval technické srovnání mezi nejlepšími elektromobily a rovnocenně srovnatelným hybridním vozem na trhu hlavního proudu. Poté, abych nakonec odůvodnil srovnání, jsem vyvinul matematický model ekonomické analýzy elektromobilu a hybridního automobilu s cílem zjistit náklady na řízení elektrického auta (elektromobilu) na rozdíl od hybridního automobilu a poté uzavřít dobu návratnosti elektrického vozidla tak, aby byly kompenzovány vyšší kapitálové investice hybridního automobilu. Tuto ekonomickou analýzu najdete v souboru Excel nazvaném „Česká ekonomická analýza EV a hybridů“ pro podmínky českého trhu.

Hlavním cílem bylo zjistit, zda elektromobily drží jasnější budoucí možnosti na rozdíl od hybridních automobilů, či nikoli, s odkazem na hlavní problémy technologie, ekonomiky a především ekologie.

Klíčová slova:

Elektromobily, Rekuperační brzdění, Řízení u / f , Interkalace, Statista, Bloomberg, BMS, CHAdeMO, CCS, Superchargery, Analýza výkonu, Matematicky simulovaná realita, Dynamická analýza, Pythagorejský trojúhelník, Rekuperační účinnost, Účinnost řízení řízení, Výpočet energetické účinnosti založený na spotřebě, Proces výroby suchých elektrod, Grafen, Silikonová nanotechnologie, Pevný elektrolyt, LiSiCON, Baterie v pevném stavu, Ultrakapacitor, Technologie Nano Flow Cell, Fisker EMotion, Česká ekonomická analýza EV a hybridů, Doba návratnosti, NCE, Americký trh, ekologie.

Table of Contents

List of Figures	vii
List of Tables	ix
1 Introduction.....	1
2 Survey of Electromobiles	4
2.1 Electric Motors:.....	13
2.2 Regenerative Breaking:.....	18
2.3 Drive Train/ Power Train:.....	18
3 Batteries	20
3.1 Best Leading Battery Manufacturers in Automobile Market.....	20
3.2 Types of Batteries:.....	21
3.2.1 Types of Rechargeable Batteries and their specifications:.....	21
3.2.2 Why Lithium Batteries are taking over Market?.....	30
3.2.3 In regards to Format and Arrangement of Cells:	32
3.2.4 Cooling Methods for Batteries:.....	36
4 Survey about Charging Stations in Europe.....	38
5 Performance Analysis of Electric Cars.....	41
5.1 Assumptions:.....	41
5.2 Approach to perform Analysis:	43
5.3 Equations used to perform Calculation:	44
5.4 Results of the analysis:	51
6 Survey of Future Trends of Electro-mobility	52
6.1 Dry Electrode Manufacturing Process Technology:	52
6.2 Future Batteries:	54
6.2.1 Graphene:.....	54
6.2.2 Silicon Nano-Technology:	55
6.2.3 Solid Electrolyte Batteries	56
6.2.4 Solid state Batteries	58
6.3 Circuit Boost Using Ultra Capacitors: [41]	59
6.4 Non- Contact Battery Charging for EVs:	59
6.5 Other Technologies:	59
7 Comparison between Electromobiles and Hybrid Car	60
8 Conclusion	63
Nomenclature & Acronyms.....	69
References	72
Appendix.....	74

List of Figures

Figure 1.1 Propulsion Methodology of Different Vehicles along with Drive Trains [1]	2
Figure 1.2 Energy diversification of EVs [2]	3
Figure 2.1 Tesla Model S	4
Figure 2.2 Nissan Leaf S Plus	5
Figure 2.3 BMW i3s.....	6
Figure 2.4 Mitsubishi iMiEV.....	7
Figure 2.5 Jaguar I-Pace	8
Figure 2.6 KIA Soul EV	9
Figure 2.7 VW e-Golf Executive Edition	10
Figure 2.8 Audi e-tron Quattro Ed.1 (SUV) Prestige Version.....	11
Figure 2.9 Smart EQ Fortwo EV (Pure, Coupe)	12
Figure 2.10 Equivalent circuit of Induction Motor [4]	13
Figure 2.11 Torque Vs. Speed characteristic of Induction Motor [5]	16
Figure 2.12 V- Curve of Synchronous Motor [6].....	16
Figure 2.13 PMSM Torque – Speed Characteristics [8].....	17
Figure 2.14 Principal of Regenerative Breaking [9]	18
Figure 2.15 Speed control through PWM in an Electronic Control Drive [10]	19
Figure 3.1 Global Market % Share of Lithium Ion Battery manufacturers [11].....	21
Figure 3.2 Ni-Cd Cell [13].....	22
Figure 3.3 Lead Acid Battery [14]	23
Figure 3.4 Lithium Ion Battery [15].....	24
Figure 3.5 Energy Densities of Li-ion Battery Chemistries [16]	30
Figure 3.6 Average Price in USD/ kWh for Li-ion Batteries [18]	32
Figure 3.7 Li-ion Cell Formats [19].....	33
Figure 3.8 Battery Modules with BMS (a) BMW i3s, (b) Tesla Model 3 [21].....	35
Figure 4.1 Charging Facility Map Across Europe [23]	38
Figure 5.1 (a) Altitudinal Map and (b) Longitudinal Map Between Prague and Brno [25]	41
Figure 5.2 Pythagorean Depiction of Road	44
Figure 6.1 Discharge voltage profile of dry coated NMC811 cathode (top) and dry coated silicon-graphite composite anode (bottom) half-cell. [36].....	52
Figure 6.2 Discharge rate performance of dry coated NMC111/graphite full-cell in comparison to wet coated NMC111/graphite full-cell. Electrode loading is 5mAh/cm ² . Cut-off voltage was 4.2V and 2.8V for charge and discharge, respectively. [36]	53
Figure 6.3 Cycle performance of dry coated NMC/graphite electrode in a prototype pouch cell at constant current 0.5C charge/1C discharge: Electrode loading- 4mAh/cm ² . Cut-off voltage was 4.2V and 2.7V for charge and discharge, respectively. [36].....	53
Figure 6.4 Graphene Nano-Structure [37]	54

Figure 6.5 Cycles vs Capacity Graph [37]	55
Figure 6.6 (a) Schematic; (b) Annual dark-field TEM image and (c) corresponding EDX elemental mappings of O, Al, Si, and Cu for the Cu-Si-Al ₂ O ₃ nanocables; [38]	55
Figure 6.7 cycle performances at a rate of 0.05 and 0.2.....	56
Figure 6.8 Existing Solid Electrolytes [39]	56
Figure 6.9 An Alkali-Metal/Aqueous Cathode Cell with Solid Electrolyte [39].....	57
Figure 6.10 Voltage discharge of an Li/Li-glass/dielectric plasticizer + LNMO + C in Al current collector cell. (a) discharge cycles; (b) charge and discharge capacity as a function of cycle number (circle around first charge). [40]	58
Figure 7.1 Systems Architectures of HEVs [42]	60
Figure 8.1 Range and Energy Consumption Graph for different Electric Car Models	64
Figure 8.2 Acceleration vs. Top Speed Graph of Different Electric Cars	65

List of Tables

Table 3.1 Lithium Manganese Oxide Table [16]	25
Table 3.2 Lithium Nickel Manganese Cobalt Oxide [16]	26
Table 3.3 Lithium Iron Phosphate [16].....	27
Table 3.4 Lithium Nickel Cobalt Aluminum Oxide [16]	28
Table 3.5 Lithium Titanate [16]	29
Table 3.6 Available Minerals in Earth Crust in % [17]	31
Table 3.7 Coolant Strategies of Different manufacturers along with their Battery Pack Details [22]	37
Table 4.1 Different Types of Chargers Used for EVs [24]	39
Table 5.1 Weather and car Constants [27], [28], [29], [30], [32], [33]	42
Table 5.2 Efficiency and Driving Efficiency	43
Table 5.3 Efficiency Table at Top Speed 90 kmph [31], [34], [35]	49
Table 5.4 Efficiency Table at Top Speed 120 kmph [31], [34], [35]	49
Table 5.5 Energy Statistics at Top Speed 90 kmph	51
Table 5.6 Energy Statistics at Top Speed 120 kmph	51
Table 7.1 Comparison Table for Tesla Model 3 and KIA Optima [43], [44], [45], [46], [47]	61
Table 8.1 Basic Specification Table for All Surveyed Models	63

1 Introduction

We live in ever changing world in dynamic universe. Life force always relies on Energy. Our search for energy to ease our lives has led us to apply systematic and innovative approach to understand the plane we live in, that we call as Science. We search for different energy sources since men first invented Fire and Wheel. Fire and Wheel are in the foundation of almost all of our technologies even these days. Since the Industrial Revolution age, we have been heavily dependent on Fossil Fuel based technologies to supply all our utilities with energy. For more than 100 years we have been depending on Hydrocarbons to meet up with energy demand. But, with time being Inevitability of our reality and our increasing demand of Fuel with increasing Global Population, we are moving towards scarcity of Hydrocarbons and their price escalations have been destabilizing economies or causing energy crises in many developed and developing countries in recent years such as Australia, Venezuela and so on.

Automobiles are one of the most basic needs of modern men. We have been using Internal Combustion engines for about 100 years now, to keep our automobiles running. But, due to increasing scarcity of fuel we are ought to find another reliable source of energy to fulfill our energy demand. Hence, in recent years we have made noticeable progress in Electromobiles, because of the fact that the electromobiles use Electricity as the source of energy. In modern days the whole world is contributing to develop more reliable and non-conventional sources of energy which are of-course more often stored in the form of electricity. Disregard of form of storage of this harvested energy (e.g., Hydro Energy or Tidal Energy); we can only supply them to our utilities in form of electricity using known technologies worldwide. This is why for transportation purpose; the upcoming future is of electromobiles. About 14 years ago around year 2006, Electromobiles were so inferior as compared to modern days Electromobiles in global markets and so is the truth with respect to Fossil fuel automobiles as well. But, since revolutionary Technologies introduced by Tesla, the world has reached new horizons when it comes to Electromobiles and many renowned car companies such as BMW, Nissan, Renault and so on has actively participated in this act of exploring new horizons to fulfill our needs.

This is also important in regards to global carbon footprint as that our planet is at the cusp of global atmospheric degradation and this has impact on all the life forms globally including humans. There is a lot of carbon emission occurring worldwide by automobiles which holds highest emission next to emission due to industries. Thus, revolutionary advancement in Electromobiles has now become an inevitable objective to humanity to balance between nature and needs. In the following paragraph we can learn more about different propulsion systems for vehicles in regards to type of energy sources they consume based on their technological principles of operation.

[2] Basic classification of on road Transport Vehicles can be done as followings,

1. Internal Combustion Engine
2. External Combustion Engine
3. Hybrid Vehicles
4. Electromobiles

[2] Based on fuel and type of drive system employed, Vehicles can be classified as below.

- a. Internal Combustion Electric Vehicle (ICEV)
- b. Full Hybrid Electric Vehicle (FHEV)
- c. Micro Hybrid Electric Vehicle (Micro-HEV)
- d. Mild Hybrid Electric Vehicle (Mild-HEV)
- e. Plug-in Hybrid Electric Vehicle (PHEV)
- f. Robotic Enhanced Vehicles (REV)
- g. Fuel Cell Electric Vehicle (FCEV)
- h. Pure Electric Vehicles (PEV) aka Battery Electric Vehicle (BEV)

As per previously seen classification flow, automobiles mainly consume Conventional Hydrocarbon fuel (IC Engines), Electricity (Most HEVs) and Hydrogen or other fuel cells such as Salt Water (FCEVs). Pure Electric Vehicles are also called as Battery Electric Vehicles.

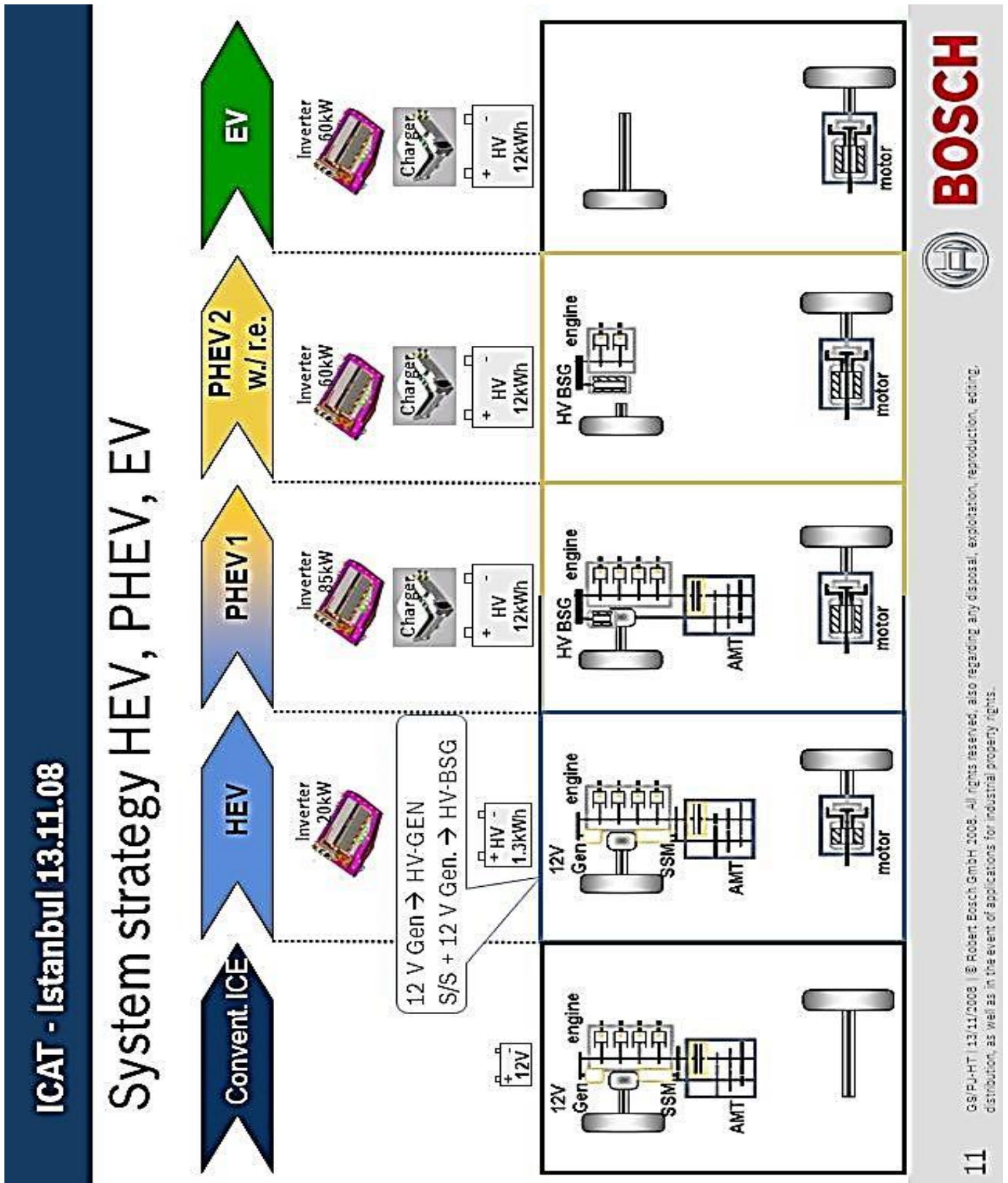

Figure 1.1 Propulsion Methodology of Different Vehicles along with Drive Trains [1]

Figure 1.1 gives perfect pictorial understanding of some key component mechanisms characterizing a particular type of engine

In the following figure 1.2, we can observe transmission of energy from source to vehicle by various means depending upon type of design and principle of operation of particular vehicle type. It may use one or multiple sources of energy depending upon their design and technology used.

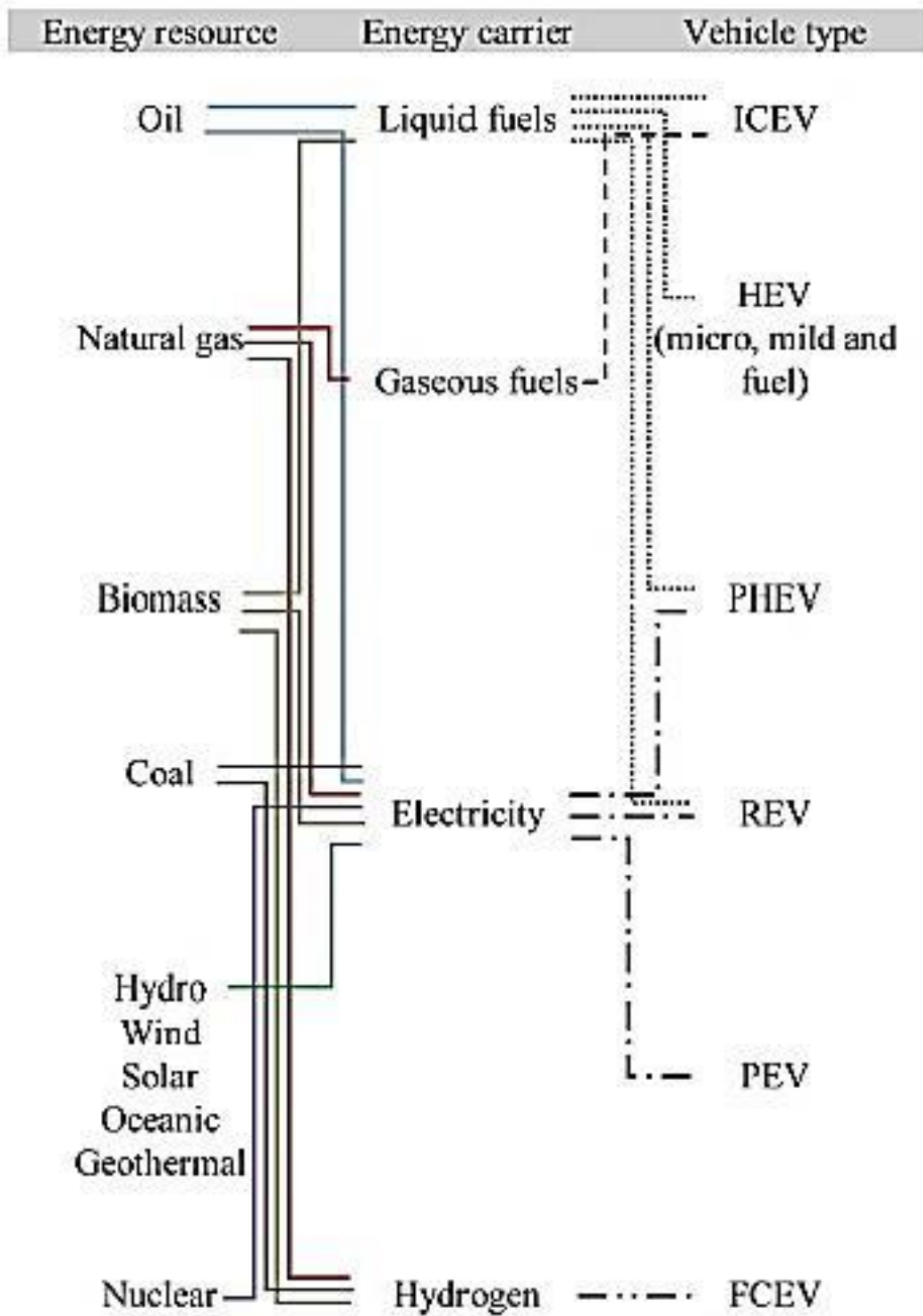

Figure 1.2 Energy diversification of EVs [2]

2 Survey of Electromobiles

In this chapter you will go through a survey of Electromobiles manufactured by the companies all over the world. These Electromobiles fall under category of PEVs aka BEVs. Here you will go through performance statistics of models of globally renowned brands of cars. This section only includes launched cars before 2019.

Here, emphasize has been given to basic Statistics like, Range (Km), Top Speed (kmph), Electric Energy Consumption (Wh/ km), Weight of Car (Kg), Acceleration 0 – 100 kmph, Price (USD and Kč) and also to detailed engineering information in regards to Power Train, Battery and Charging technologies availed by Car manufacturer.

In this section I have displayed survey of Electrical Vehicles available in markets of USA with their standard average price, so as to have an idea of costs for car in a particular country market.

Model Name: [Tesla Model S](#) [3]



[Figure 2.1 Tesla Model S](#)

Statistics:

Range (Km): 434.52 – 506.94 (539*) km

Top Speed (kmph): 249.44 kmph

Electric Energy Consumption: 17.5 kWh/ 100 km

Weight of Car: 2027 Kg

0 – 100 kmph: 2.4 Sec

Price (USD): \$69,750 - \$89,750 (\$104,750*)

Technical Specifications:

Powertrain:

- Three phase, four pole AC induction motor with copper rotor, liquid cool with VFD.
- Nominal Voltage: 320 V
- Rear Motor:

- RPM: 16000
- Maximum Power: 193 kW @ 6850 rpm
- Maximum Torque: 440 Nm
- Front Motor:
 - RPM: 18000
 - Maximum Power: 193 kW @ 6100 rpm
 - Maximum Torque: 330 Nm
- [3] Drive inverter with variable frequency drive and regenerative braking system
- AWD

Battery and Charging:

- Model S microprocessor controlled, lithium-ion battery
- Rating: 33 A*h
- Customized options available: 60, 70, 75, 85, 90, or 100 kWh (at beginning of life)
- Nominal Voltage:
 - For 85, 90, and 100 kWh: 350V DC
 - For 85, 90, and 100 kWh: 300V DC
- Temperature Range:

Do not expose Model S to ambient temperatures above 140° F (60° C) or below -22° F (-30° C) for more than 24 hours at a time.

- Liquid Cooled
- Supercharger enabled
- Compatible with Tesla Wall Connector
- 240 volt NEMA 14-50 adapter
- 120 volt NEMA 5-15 adapter
- J1772 public charging adapter
- Charging Hours: 5 hour

Model Name: [Nissan Leaf S Plus](#) [3]



[Figure 2.2 Nissan Leaf S Plus](#)

Statistics:

Range (Km): 363 km

Top Speed (kmph): 193.12 kmph

Electric Energy Consumption: 17.1 kWh/ 100 km

Weight of Car: 1557.18 Kg

0 – 100 kmph: 7.3 s

Price: Model S Plus: \$36,550 (\$29,050 after Federal tax)

Technical Specifications:

Powertrain:

- Front Wheel Drive
- High-response AC synchronous motor
- Motor Power: Model S Plus: 160 kW MOTOR
- Torque: Model S Plus: 338.954 Nm
- Front motor/ front-wheel drive

Battery and Charging:

- 62 kW Laminated lithium-ion battery with 24 compact, eight-cell modules
- 6.6 kW onboard charger
- Quick Charge Port - 50 kW
- Quick Charge Port - 100 kW
- Charging Hours: 3 Hours
 - Portable charge cable (120 V/240 V): Plug into 240-V wall outlet – no charging box required
 - Available Quick Charge Port – allows charging to 80 percent capacity in 40 minutes at fast-charging stations (standard on SV and SL, optional on S)

Model Name: [BMW i3s](#) [3]



[Figure 2.3 BMW i3s](#)

Statistics:

Range (Km): 246.22 km

Top Speed (kmph): 149.669 kmph

Electric Energy Consumption: 16.5 kWh/ 100 km

Weight of Car: 1648 Kg

0 – 100 kmph: 7.2 Sec

Price: \$44,450

Technical Specifications:

Powertrain:

- AC Synchronous Electric Motor with integrated power electronics, charger and generator mode for recuperation
- All-electric 170-hp @ 4800 RPM and 385.052 Nm of torque @ 0 RPM
- EDRIIVE MOTOR TORQUE (269.808 Nm @ 0 rpm)
- Rear Wheel Drive

Battery and Charging:

- 42 kWh high-voltage lithium-ion battery pack with advanced active thermal management system
- J1772 AC Fast charging capability (7.4 kW): 4.9 hours
- DC Fast charging capability (SAE Combo connector): 0.7 hours (0 – 80%)

Model Name: [Mitsubishi iMiEV](#) [3]



[Figure 2.4 Mitsubishi iMiEV](#)

Statistics:

Range (Km): 150 km

Top Speed (kmph): 130 kmph

Electric Energy Consumption: 125 Wh/ km

Weight of Car: 1090 Kg

0 – 100 kmph: 15.9 Sec

Price: \$27,998

Technical Specifications:

Powertrain:

- AC synchronous permanent magnetic motor
- 66 hp @ 4000 rpm
- Maximum Torque: 196 Nm
- Rear Wheel Drive

Battery and Charging:

- 330V, 16 kWh Lithium-Ion batteries
- Charging Hours:
 - Regular Charging 230V, 1- Φ , 16A = 6 hours
 - Regular Charging 230V, 1- Φ , 10A = 8 hours
 - Regular Charging 230V, 1- Φ , 8A = 10 hours
 - Fast Charging = Approx. 30 minutes.

Model Name: [Jaguar I-Pace](#) [3]



[Figure 2.5 Jaguar I-Pace](#)

Statistics:

Range (Km): 470 km

Top Speed (kmph): 200 km/h

Electric Energy Consumption: 22.0 kWh/100km

Weight of Car: 1580 Kg

0 – 100 kmph: 4.5 Sec

Price: \$69,500

Technical Specifications:

Powertrain:

- All-electric 400 ps (294.19 kW) and 249.471 Nm of torque motor
- Two extremely lightweight and compact Synchronous Permanent Magnet Electric Motors (aka PMSM)
- 2 motors, separate for FWD and RWD
- EDRIIVE MOTOR TORQUE (269.808 Nm @ 0 rpm)
- AWD

Battery and Charging:

- 90kWh battery is constructed of high energy density lithium-ion pouch cells
- Charging Hours:
 - Home Charging: AC 7kW 0-100% Charge
 - Public Charging: DC 100kW Up To 100km Of Range In 15 Minutes

Model Name: [KIA Soul EV](#) [3]



[Figure 2.6 KIA Soul EV](#)

Statistics:

Range (Km): 249.448 km

Top Speed (kmph): 144.841 kmph

Electric Energy Consumption: 143 Wh/ km

Weight of Car: 1580 Kg

0 – 100 kmph: 11.00 Sec

Price: \$35950.19

Technical Specifications:

Powertrain:

- Interior Permanent Magnet Synchronous Motor (IPMSM) (3 Phase)
- Max. power, bhp at rpm = 109 / 2,730 - 8,000
- Max Power = 81.4 kW
- Max. torque = 285 Nm at 0 till 2,730 rpm

Battery and Charging:

- Charging Hours: 4.9 Hour (AC) and 0.7 Hour (DC) for 50kW i.e., 80% capacity
- Electric 30kWh lithium-ion polymer battery
- Number of Cells = 192
- Nominal Voltage = 375V
- 3-pin AC Charger (AC single-phase charging up to 2.3kW (230V x 10A)): 11-14 hours (0% g 100%)
- J1772 AC Charger (AC single-phase charging up to 6.6kW (230V x 30A)): 4-5 hours (0% g 100%)
- DC Charge Time (DC triple-phase charging up to 50kW (380V x 125A)): 33 minutes (0% g 80%)

Model Name: [VW e-Golf Executive Edition](#) [3]



[Figure 2.7 VW e-Golf Executive Edition](#)

Statistics:

Range (Km): 190 km

Top Speed (kmph): 140 km/h

Electric Energy Consumption: 16.7 kWh/ 100 km = 167 Wh/ km

Weight of Car: 1659 Kg

0 – 100 kmph: 10.4 Sec

Price: \$46046.73

Technical Specifications:

- Rear:
 - Coaxial, Asynchronous Motor
 - Torque: 355 Nm
 - Total system torque with boost Nm: 664
- Front:
 - Axially Parallel, Asynchronous Motor
 - Torque with boost: 309 Nm

Battery and Charging:

- 396 V, 95 kWh lithium-ion battery pack
- Battery - 380A / 68Ah
- Advanced cell technology
- Liquid cooling design
- Number of cells: $36 * 12 = 432$ (unequally distributed in 27 modules)
- Number of Modules: 36
- Charging Hours:
 - Charging 0-100% on AC 9.6 kW (hours) - About 9 hours
 - Charging on 0-80% on DC 150 kW (minutes) - About 30 minutes

Model Name: [Smart EQ Fortwo EV \(Pure, Coupe\)](#) [3]



Figure 2.9 Smart EQ Fortwo EV (Pure, Coupe)

Statistics:

Range (Km): 145 km

Top Speed (kmph): 130 km/h

Electric Energy Consumption (kWh/ 100 km): 12.9 = 129Wh/ km

Weight of Car: 1,285 kilograms

0 – 100 kmph: 11.5 Sec

Price: \$23,900

Technical Specifications:

Powertrain:

- Separately excited three-phase synchronous motor
- Direct drive transmission, RWD
- Max. power output in 60 kW
- Max. torque in 160 Nm

Battery and Charging:

- 17.6 kWh lithium-ion
- Number of battery cells 96
- On-board charger in kW 4,6
- Charging Hours:
- Charging time 20-100% in hours at a wall box: 3.5 hrs.
 - Charging time 20-100% in hours at a domestic power socket box: 6 hrs.

2.1 Electric Motors:

There are mainly following types of motors used in EVs,

- Asynchronous Motor Single Phase and 3 Phase:

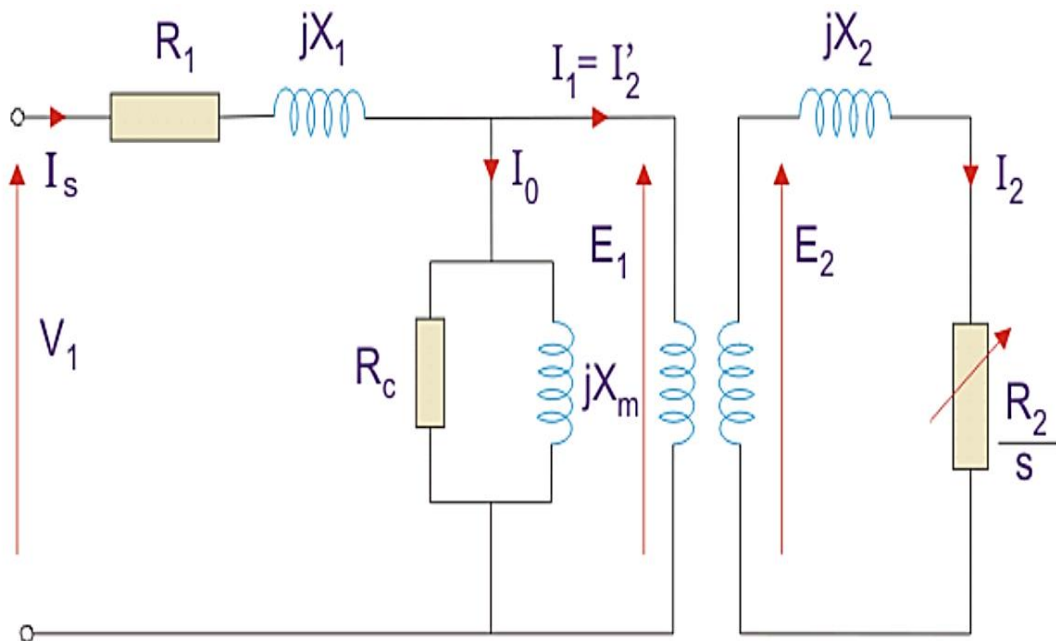

Figure 2.10 Equivalent circuit of Induction Motor [4]

It works mainly on the principle of transformer action, but there is much to elaborate that you will see in the followings. Any motor comprises of 2 fundamental parts, Stator and Rotor. Asynchronous Motors are also called as Induction Motors. In easy words, in these types of Motors a rotor cannot magnetically lock into RMF of Stator and this is why they are called as Asynchronous Motor. Magnetic locking with RMF is called as Synchronism. Rotor of a motor cannot catch up with RMF mainly due to Inertia of Rotor. This problem is called as Slip which can be derived from following equation.

$$\frac{N_s - N}{N_s} * 100 = S = \frac{\text{Rotor Copper Loss}}{\text{Rotor Input}}$$

..... Equation 2.1

Where,

$$N_s = \frac{(60 * f)}{\left(\frac{P_p}{2}\right)}$$

... .. [Equation 2.2](#)

N_s = Synchronous Speed of RMF

S = Slip

N = Actual Speed of Rotor

P = Number of Poles = $P_p/2$, Where P_p is pole pairs

Also, it is not possible to self-start an Induction Motor without a starting arrangement and for this purpose 3 methods are used.

- Capacitor Start
- Shaded Pole
- Split Phase

Maximum value of slip can be 1 and Minimum value is 0.

Thus, when the motor is in stand still condition,

$N = 0$ and $S = 1$

When Motor is running at Synchronous Speed,

$S = 0$.

When Motor works as Generator,

$S = -1$

Principle of Operation and Working:

Induction Motor works on the principal of mutual induction. An e.m.f. is induced in a conducting coil when it is rotated in an equally distributed magnetic field B as per Faraday's law. The direction of induced e.m.f in the coil is always such that it opposes the very field that caused it as per Lenz's Law. Thus, following equation gives understanding of this principle of operation.

$$\text{Faraday's Law, } \epsilon = -N \frac{\partial \Phi_B}{\partial t}$$

... .. [Equation 2.3](#)

Here, negative sign in the equation shows opposite direction of mutually induced emf in the coil that reflects effect of Lenz's Law.

ϵ = Induced emf in the coil

Φ_B = Stator Flux of field B (aka Uniform Magnetic Field)

N = Number of turns in a coils, t = Time

Equation above clearly explains that emf generated in the rotor is opposite to that of stator. Thus, stator and rotor have opposite polarities, this means that if pole on the Stator would be north then the nearest end of Rotor to the Stator would be south and this is why Rotor will be attracted to Stator due to opposite polarities. This is how law of conservation of energy is also fulfilled. The rotor always tends to catch the rotating pole of Stator and come to rest. But, Stator poles are rotating in nature and that is why in efforts of catching the R.M.F. rotor starts rotating at speed near to Synchronous Speed (N_s). But, as soon as Rotor reaches Synchronous Speed, the relative motion between Rotor and Stator poles become zero and this is why rotor no longer cut the magnetic line of forces and it loses its magnetism and this is when friction and other losses play their role and pulls down the speed of Rotor. This is when again there is relative motion between stator poles and rotor and thus rotor again starts cutting magnetic line of forces of

Stator poles and gets magnetized and this cycle repeats over and over again as long as Stator is supplied electricity.

Torque equation Asynchronous Motor for Single Phase: [4]

$$T = k * \Phi_B * I_2 * \cos \theta_2$$

... .. Equation 2.4

Where,

T = Torque

Φ = Stator Flux that produces emf in Rotor

I_2 = Rotor Current

$\cos\theta_2$ = Power factor of rotor circuit

The flux ϕ produced by the Stator is proportional to the Stator emf E_1 , i.e, $\phi \propto E_1$

We know that transformation ratio K is defined as the ratio of secondary voltage (rotor voltage) to that of primary voltage (stator voltage).

$$K = \frac{E_2}{E_1}$$

... .. Equation 2.5

OR

$$K = \frac{E_2}{\Phi}$$

... .. Equation 2.6

OR

$$E_2 = \Phi$$

... .. Equation 2.7

Thus, from previous equations, Torque equation for a 3-Phase Induction motor can be derived as under, [4]

$$T = \frac{s * E_2^2 * R_2}{R_2^2 + (sX_2)^2} * \frac{3}{2\pi N_s}$$

... .. Equation 2.8

OR

$$T = K * s * E_2^2 * \frac{R_2}{R_2^2 + (sX_2)^2}$$

... .. Equation 2.9

Where,

$$K = 3/2\pi n_s$$

... .. Equation 2.10

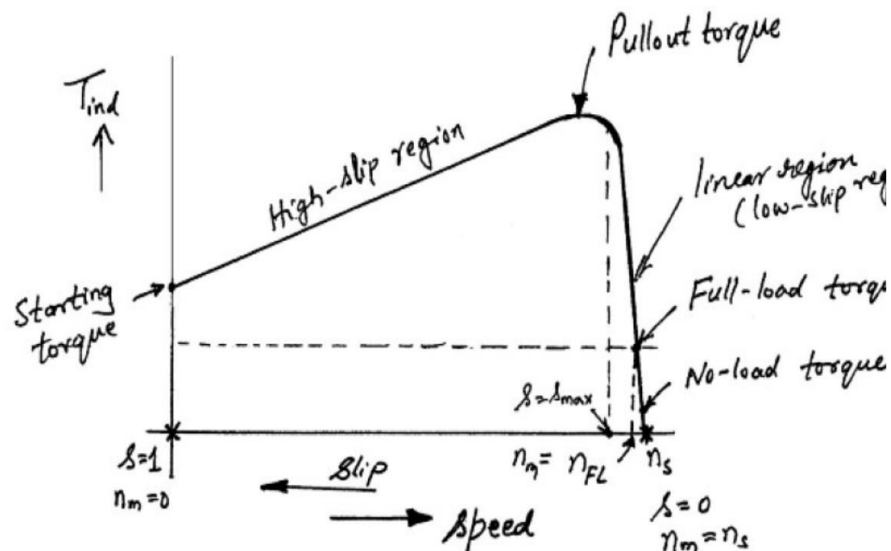

Figure 2.11 Torque Vs. Speed characteristic of Induction Motor [5]

➤ Synchronous Motor

[6] Synchronous Motors are constructionally and principally much similar to an Induction Motor, except that the rotor is also provided with separate DC excitation or in some case permanent magnets. The name Synchronous motor comes due to ability of Motor Rotor to Synch with RMF of Stator. But, to attain this motor initially starts like an Induction Motor using a squirrel cage rotor so that it can attain speed closer to synchronous speed so as to overcome inertia and then as soon as Speed of Rotor reaches Synchronous Speed the DC supplied Rotor Poles locks into synchronism with RMF. At this instance the rotor stays in synchronism with RMF and thus relative speed between Stator and Rotor becomes zero. Thus, squirrel cage no longer cuts line of flux from Stator and gets de-energized and rotor only rotate because of Synchronism between Stator RMF and Rotor. The synchronous motors are not self-start and so for this reason as well a squirrel cage can be provided.

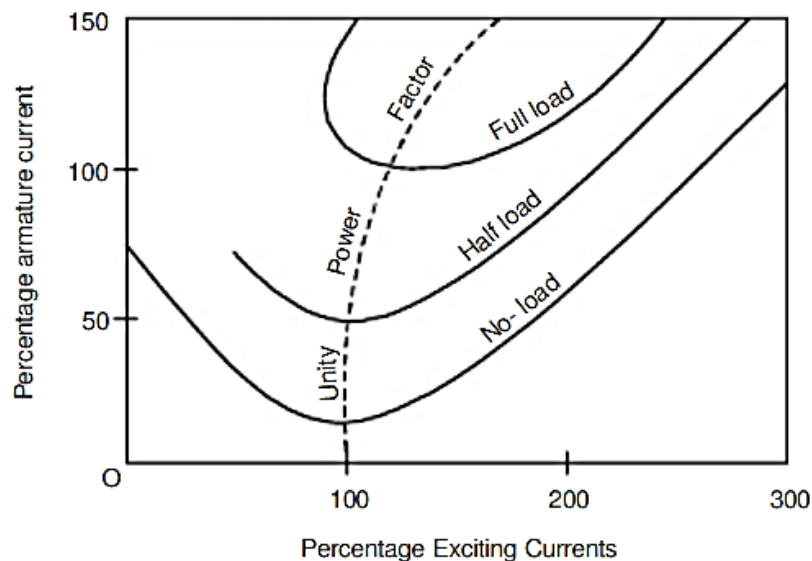

Figure 2.12 V- Curve of Synchronous Motor [6]

If the excitation current is varied, the armature current also varies. If the curve is plot for armature current and excitation current, the plot takes shape of latter "V". Thus the curve is

called as V curve. As shown in the Figure No- 2.12, for particular value of Armature current against Excitation current we get Unity Power Factor, this is represented by the discontinuous line in the Figure No- 2.12. The region on the left is region of lagging power factor as a result of under excitation. While the region right to the discontinuous line shows leading power factor due to over excitation. The excitation current may also be called as Field current. The only drawback of this motor for using in Electromobiles is that speed control for this motor is a bit complex as compared to that in the case of Induction Motor.

➤ Permanent magnet synchronous motor

As the name itself suggests PMSM is a Synchronous Motor, except that it has Permanent Magnet Rotor. As the Rotor is Permanent Magnet in nature the single phase stator configuration for this Motor as well is not self-start. For this reason we need to use either closed loop system by means of a Motor driver that allows system to know the position of the rotor by means of position encoder. But, for open loop approach some modern researches employees Squirrel Cage winding in the Rotor.

$$T_e = \frac{3p}{2} [\psi_m i_q + (L_d - L_q) i_d i_q]$$

... .. Equation 2.11 [7]

Where, [7]

T_e is Mechanical Torque

P is the number of pole pairs of the PMSM.

ψ_m is the flux linkage of the permanent magnet.

L_d and L_q are the d- and q-axis inductances of the PMSM.

i_d and i_q are the d- and q-axis currents of the PMSM.

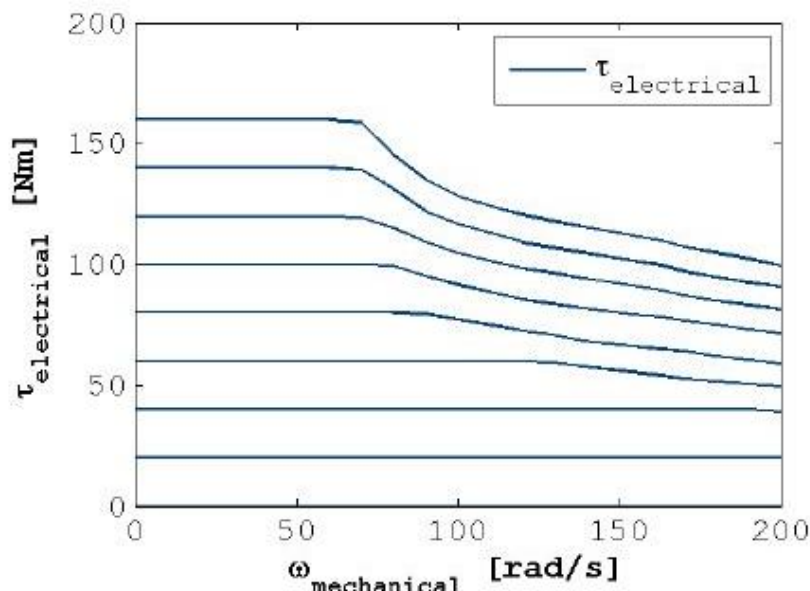

Figure 2.13 PMSM Torque – Speed Characteristics [8]

Usually this motor is utilized in low load application. Due to that load capacity of this type of motor is limited. Due to this is suddenly high load torque is applied then possibility of increasing load angle in this motor is not available due to absence of damper winding. Thus, sudden increase at Higher Load Torque pulls the motor out of Synchronism and so Motor stops working.

2.2 Regenerative Breaking:

Regenerative breaking is a technology that is provided to ensure that vehicle energy during breaking or deceleration does not get wasted in friction and heat. Also this ensures improved control of car driving experience. This is achieved by running the very motor that drives car in generation mode. Theoretically, the Motor starts running at $S = -1$, as shown in Figure No- 2.14. Thus when the driver stop accelerating car, then car stops with very small free running time and this is how emergency breaking of car gets extra help for retardation of car through motors. The generated energy is then sent back to Super Capacitors or to the battery pack depending upon electrical circuit analogy used in the vehicle.

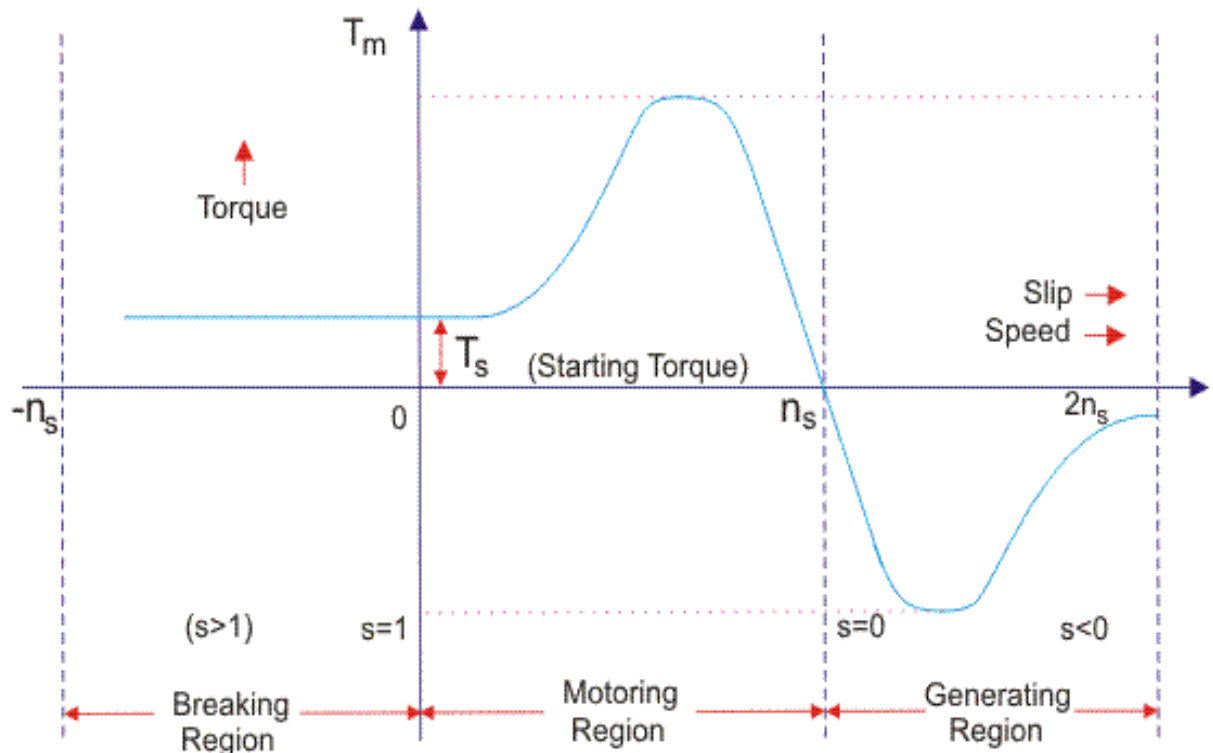

Figure 2.14 Principal of Regenerative Breaking [9]

2.3 Drive Train/ Power Train:

Drive train is motor to wheel power transmission arrangement. But, in most Electrical cars, Power transmission system is not so complex as opposed to conventional fuel or Hybrid Cars. Because, most of the Electrical Cars use Induction Motor and for this reason to attain speed control of car is possible with minimum transmission and governing losses. But, for cars with constant speed motors, i.e. cars with Synchronous Motor or PMSM, has respectively complex speed control mechanism as compared to that in case of Induction Motor, because it's not possible to control speed of Synchronous motor like in case of Induction Motor.

[10] To achieve speed control Induction Motor, electronic drive is used. In this electronic drives input current to the Induction Motor is regulated. This current regulation is achieved by PWM method. PWM is generally achieved by a vital component called IGBT. The IGBT provides controlled power output to the motor. By doing this we can achieve voltage control. Thus we can achieve speed control. Another way to achieve speed control is by means of changing frequency of carrier signal that performs switching of IGBT. This control method is commonly known as v/f control.

Thus, after Modulation the output waveform of modulated supply current to the motor looks as shown in Figure No-2.15.

OUTPUT CURRENT WAVEFORM

(ONE PHASE SHOWN)

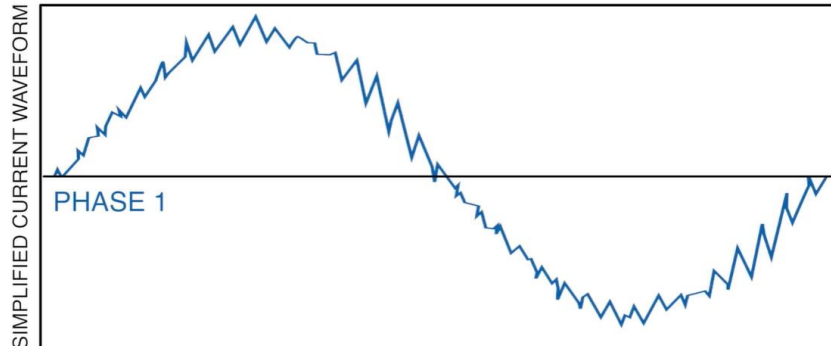

Figure 2.15 Speed control through PWM in an Electronic Control Drive [10]

[10] The v/f control can be explained by following equations.

$$X_L = 2\pi fL$$

... .. Equation 2.12

But, $X_L I = V$

... .. Equation 2.13

Thus, $2\pi fLI = V$

... .. Equation 2.14

Where,

f = Modulated Supply Power Frequency

V = Supplied Voltage

I = Supplied Current

X_L = Inductive Component of Impedance

L = Inductance

Thus, as you can see in above Equation-2.14, there is a direct proportionality between Supplied Frequency and Voltage. This is how V/f method works. By just changing the Supplied Frequency by using a Control Drive, we can easily control the speed of a motor. In much variable load torque applications voltage control is also possible. But, for constant torque load applications sometimes changing voltage is not feasible. Followings are standard control methods used Control Drives:

- V/f = Voltage by Frequency
- V/f with Pulse Generator
- Open Loop Vector
- Closed Loop Vector
- Permanent Magnet Options

3 Batteries

This is the most important key component for Electromobile Technology. As that Battery Packs is the most expensive part of Electromobile. In an electrically supplied vehicle, a battery acts as an “Energy Storage Device”. In this regards, the product’s market dominance depends on the best and the most advanced battery technology owned by a company. To be a leader in Electromobile Market, a manufacturer must be improving battery technology and should stay ahead of other competitors. Improving Power Transmission circuit by adding up devices like a super capacitor may also be a smarter move.

Prior to moving more into details of Batteries, it is a wise idea to understand “what really a Battery is?” A Battery is actually a group of Cells that works on the laws of Chemistry and Physics. A cell often consist of mainly 3 components namely Cathode, Anode and Electrolytes and works on Principles of Redox process. Word Redox comprises 2 types of reaction Reduction and Oxidation. Reduction Happens on Cathode and Oxidation happens on Anode. The Electrolyte may be Liquid and in modern Technologies it can be Gas or Solid as well. New more advanced technologies use Solid Electrolytes that we will see in Chapter-6. Hence, from this one can easily understand that scopes of improvement of Batteries or to be precise let’s say for Cells is in improving Cathode, Anode and Electrolyte not only chemically but also geometrically (Physically).

Scopes for improving battery technology depends on,

- a) Elements used to manufacture and their economic analysis in regards to energy potential and availability of raw resources
- b) Study of physical and chemical properties
- c) Architecture (Geometrical and Physical Innovative Stance) used to manufacture battery pack
- d) Cooling methodology used to maintain life

In the following part of this chapter, you may refer to above mentioned concepts in more detail,

Intercalation Definition: In [chemistry](#), **intercalation** is the reversible inclusion or insertion of a [molecule](#) (or ion) into materials with layered structures. Examples are found in graphite and transition metal dichalcogenides. [55]

3.1 Best Leading Battery Manufacturers in Automobile Market

[11] As we just discussed previously in Chapter-2, best battery manufacturer for Electromotives are no other than those who are associated to leading car companies across the world. The names are, Panasonic, Samsung SDI, Toshiba, LG Chem, BYD, Johnson Controls, etc. All of them produce Li-Ion batteries due to excellent properties of Lithium as Cathode element.

Many of the above mentioned manufacturers have production contracts with world’s top Electrical Vehicle manufacturer companies such as Tesla, Vox-wagon Group, Nissan, Hyundai, Jaguar, and Mitsubishi and so on from Asia, Europe and North America.

Please refer to the following survey from Statista where the graph in the Figure No- 3.1 shows Li-Ion Battery global Market share for year 2018.

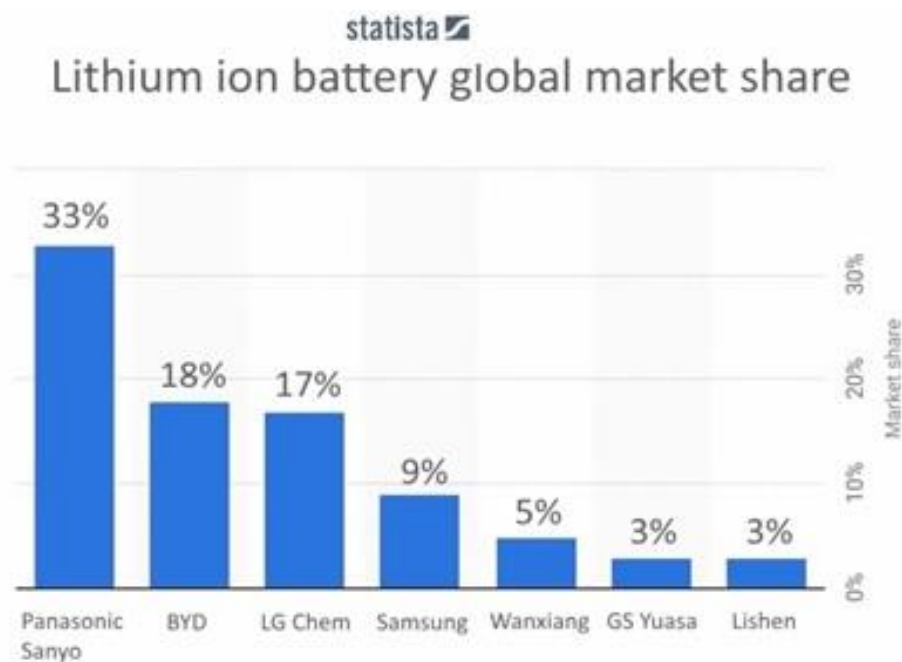

Figure 3.1 Global Market % Share of Lithium Ion Battery manufacturers [11]

Not to mention that this share in Lithium Ion battery production has been significantly increased globally after year 2012 as the world realized importance of saving Planet Earth and to substitute conventional sources of energy with non-conventional energy sources.

3.2 Types of Batteries:

In this section we will look in all basics of batteries along with its Elemental analysis regarding its Chemical and Physical properties. Batteries can be classified into two major categories Primary and Secondary.

I. Primary Batteries: [12]

These batteries can be used once only, meaning that it has no charging cycle.

Batteries such as The Alkaline batteries, Mercury batteries, Silver-Oxide batteries, and Zinc carbon batteries, etc. are examples of primary batteries.

II. Secondary Batteries: [12]

These batteries can be used many times depending on number charging cycles available. Hence, we will go into depth about secondary type of Batteries.

The major limitation that we have in regards to production of Automobile based power cell is **Weight** of an Element. We want Elements that has Higher Energy Potential yet lesser mass. Hence, world Battery Manufacturers choose light weight elements such as Lithium to manufacture Electromobile Batteries.

3.2.1 Types of Rechargeable Batteries and their specifications:

This section explains in depth about specifications such as Types, Volume, Weight, Specific Energy, Energy Density, Specific Power, Charge/discharge efficiency, Self-discharge rate, and Cycle durability/life, Advantages, Limitations and Applications for each type of Battery with the chemical reaction in the cell.

On the following pages are the types of Rechargeable Batteries that are widely used for many applications in the market.

I. Nickel Cadmium (NiCd) Cell: [12]

Positive Electrode (Cathode): Nickel oxide hydroxide (NiOOH)

Negative Electrode (Anode): Cadmium

They come in all different sizes including the sizes used for alkaline batteries, AAA, AA, A and so on.



Figure 3.2 Ni-Cd Cell [13]

➤ Specifications:

- Specific Energy: 40-60W-h/kg
- Energy Density: 50-150 W-h/L
- Specific Power: 150W/kg
- Charge/discharge efficiency: 70-90%
- Self-discharge rate: 10%/month
- Cycle durability/life: 2000cycles

➤ Advantages:

- This cell is very good at maintaining voltage and holding charge when not in use.
- It works nicely even at low temperature.
- Its best feature is that it delivers full rated capacity at high discharge rates. This would make it excellent for quick acceleration of vehicle, if used to supply an EV.

➤ Limitation: This type of cell must never be charged until it's fully discharged, If not done so then its recharging capability lowers with each recharge.

➤ Application: Ni-Cd cells come in individual pieces or assembled in packs of two or more cells. The small packs are used in portable devices, electronics and toys while the bigger ones find application in aircraft starting batteries, Electric vehicles and standby power supply.

II. Nickel-Metal Hydride (NiMH) Battery [12]

The positive electrode of batteries is similar to that of the nickel-cadmium cell (NiCd) but the negative electrodes in Nickel-Metal Hydride use a hydrogen-absorbing alloy instead of cadmium.

Positive Electrode (Cathode): Nickel oxide hydroxide (NiOOH)

Negative Electrode (Anode): Metal Hydride

- Application: **Not used in Vehicles.**

III. Lead Acid Battery: [12]

Lead acid batteries are low-cost yet reliable and used in heavy duty applications. They are usually very large.

Positive Electrode (Cathode): Lead Oxide (PbO₂)

Negative Electrode (Anode): Lead (Pb)



Figure 3.3 Lead Acid Battery [14]

- Advantages: It can supply huge surge currents when needed
- Limitation:
 - Fast Charging Impossible
 - Very Heavy in weight (due to higher Atomic mass)
 - Very low energy to volume and energy to weight ratios
 - They cannot be applied in Electromobiles as a source power to drive them due to heavy weight of Lead Acid Batteries.
- Application:
 - It has a relatively large power to weight ratio and as a result can supply huge surge currents when needed. Thus, it is used in high current applications.
 - Widely used in non-portable applications such as solar-panel energy storage, vehicle ignition and lights, laboratories, backup power and load leveling in power generation/ distribution.

IV. Lithium Ion Battery: [12]

Lithium ion batteries are one of the most popular types of rechargeable batteries. They are found in different portable appliances including

Positive Electrode (Cathode): Lithium Cobalt Oxide (LiCoO₂)

Negative Electrode (Anode): Carbon (C)



[Figure 3.4 Lithium Ion Battery \[15\]](#)

Some of the attributes of lithium ion batteries are listed below;

➤ Specifications:

- Specific Energy: 100: 265W-h/kg
- Energy Density: 250: 693 W-h/L
- Specific Power: 250: 340 W/kg
- Charge/discharge percentage: 80-90%
- Cycle Durability: 400: 1200 cycles
- Nominal cell voltage: NMC 3.6/ 3.85V

➤ Advantages:

- Lithium ion batteries generally possess high energy density, little or no memory effect and low self-discharge compared to other battery types.
- Fast Charging possible
- Light Weight
- Very high energy to volume and energy to weight ratios

➤ Limitation:

- Lithium-Ion batteries are more unsafe as compared to other batteries.

➤ Application:

- In Mobile phones, smart devices and several other battery appliances used at home. They also find applications in aerospace and military applications due to their lightweight nature.
- Widely used in non-portable applications such as solar-panel energy storage, vehicle ignition and lights,

Note that Lithium-Ion Batteries come in many options based on Chemistry implemented and so in this regards, they come basically in following 6 configurations. But, we will not go in to more explanation for sake of Thesis length; instead use of figures and tables would be a better option.

1) Lithium Cobalt Oxide [16]

Positive Electrode (Cathode): Lithium Cobalt Oxide (LiCoO₂)

Negative Electrode (Anode): Graphite Carbon (C)

This type of cell doesn't have application in manufacturing of EVs due to its higher cost and so we will not go much into the depth for this.

2) Lithium Manganese Oxide (LiMn₂O₄) [16]

Positive Electrode (Cathode): lithium manganese oxide (LiMn₂O₄)

Negative Electrode (Anode): Graphite Carbon (C)

Most Li-manganese batteries blend with lithium nickel manganese cobalt oxide (NMC) to improve the specific energy and prolong the life span. This combination brings out the best in each system, and the LMO (NMC) is chosen for most electric vehicles, such as the Nissan Leaf, Chevy Volt and BMW i3. The LMO part of the battery, which can be about 30 percent, provides high current boost on acceleration; the NMC part gives the long driving range.

Lithium Manganese Oxide LiMn₂O₄ cathode. graphite anode Short form: LMO or Li-manganese (spinel structure) Since 1996		
Sr. No.	Parameter	Details
1	Voltages	3.70V (3.80V) nominal; typical operating range 3.0–4.2V/cell
2	Specific energy (capacity)	100–150Wh/kg
3	Charge (C-rate)	0.7–1C typical, 3C maximum, charges to 4.20V (most cells)
4	Discharge (C-rate)	1C; 10C possible with some cells, 30C pulse (5s), 2.50V cut-off
5	Cycle life	300–700 (related to depth of discharge, temperature)
6	Thermal runaway	250°C (482°F) typical. High charge promotes thermal runaway
7	Applications	Power tools, medical devices, electric powertrains, EVs
8	Comments	High power but less capacity; safer than Li-cobalt; commonly mixed with NMC to improve performance.

[Table 3.1 Lithium Manganese Oxide Table \[16\]](#)

3) Lithium Nickel Manganese Cobalt Oxide (LiNiMnCoO₂ or NMC) [16]

Positive Electrode (Cathode): Nickel-Manganese-Cobalt (NMC)

Negative Electrode (Anode): Graphite Carbon (C)

They can serve as Energy Cells or Power Cells. For example, NMC in an 18650 cell for moderate load condition has a capacity of about 2,800mAh and can deliver 4A to 5A; NMC in the same cell optimized for specific power has a capacity of only about 2,000mAh but delivers a continuous discharge current of 20A. A silicon-based anode will go to 4,000mAh and higher but at reduced loading capability and shorter life cycle. Silicon added to graphite has the drawback that the anode grows and shrinks with charge and discharge, making the cell mechanically unstable. The cathode combination is typically known as 1-1-1.

Lithium Nickel Manganese Cobalt Oxide LiNiMnCoO₂. cathode, graphite anode Short form: NMC (NCM, CMN, CNM, MNC, MCN similar with different metal combinations) Since 2008		
Sr. No.	Parameter	Details
1	Voltages	3.60V, 3.70V nominal; typical operating range 3.0–4.2V/cell, or higher
2	Specific energy (capacity)	150–220Wh/kg
3	Charge (C-rate)	0.7–1C, charges to 4.20V, some go to 4.30V; 3h charge typical. Charge current above 1C shortens battery life.
4	Discharge (C-rate)	1C; 2C possible on some cells; 2.50V cut-off
5	Cycle life	1000–2000 (related to depth of discharge, temperature)
6	Thermal runaway	210°C (410°F) typical. High charge promotes thermal runaway
7	Cost	~\$420 per kWh (Source: RWTH, Aachen)
8	Applications	E-bikes, medical devices, EVs, industrial
9	Comments	Provides high capacity and high power. Serves as Hybrid Cell. Favorite chemistry for many uses; market share is increasing.

[Table 3.2 Lithium Nickel Manganese Cobalt Oxide \[16\]](#)

4) Lithium Iron Phosphate (LiFePO₄) [16]

Positive Electrode (Cathode): Lithium Iron Phosphate (LiFePO₄)

Negative Electrode (Anode): Graphite Carbon with Metallic Baking (C)

Li-phosphate is often used to replace the lead acid starter battery. Four cells in series produce 12.80V, a similar voltage to six 2V lead acid cells in series. Vehicles charge lead acid to 14.40V (2.40V/cell) and maintain a topping charge. Topping charge is applied to maintain full charge level and prevent sulfation on lead acid batteries.

Lithium Iron Phosphate: LiFePO₄ cathode, graphite anode Short form: LFP or Li-phosphate Since 1996		
Sr. No.	Parameter	Details
1	Voltages	3.20, 3.30V nominal; typical operating range 2.5–3.65V/cell
2	Specific energy (capacity)	90–120Wh/kg
3	Charge (C-rate)	1C typical, charges to 3.65V; 3h charge time typical
4	Discharge (C-rate)	1C, 25C on some cells; 40A pulse (2s); 2.50V cut-off (lower than 2V causes damage)
5	Cycle life	1000–2000 (related to depth of discharge, temperature)
6	Thermal runaway	270°C (518°F) Very safe battery even if fully charged
7	Cost	~\$580 per kWh (Source: RWTH, Aachen)
8	Applications	Portable and stationary needing high load currents and endurance, Vehicles
9	Comments	Very flat voltage discharge curve but low capacity. One of safest Li-ions. Used for special markets. Elevated self-discharge.

[Table 3.3 Lithium Iron Phosphate \[16\]](#)

5) Lithium Nickel Cobalt Aluminum Oxide (LiNiCoAlO₂) [16]

Positive Electrode (Cathode): Lithium Nickel Cobalt Aluminium Oxide (LiNiCoAlO₂)

Negative Electrode (Anode): Graphite Carbon with Metallic Baking (C)

It shares similarities with NMC by offering high specific energy, reasonably good specific power and a long life span.

Lithium Nickel Cobalt Aluminum Oxide LiNiCoAlO₂ cathode (~9% Co), graphite anode Short form: NCA or Li-aluminum. Since 1999		
Sr. No.	Parameter	Details
1	Voltages	3.60V nominal; typical operating range 3.0–4.2V/cell
2	Specific energy (capacity)	200-260Wh/kg; 300Wh/kg predictable
3	Charge (C-rate)	0.7C, charges to 4.20V (most cells), 3h charge typical, fast charge possible with some cells
4	Discharge (C-rate)	1C typical; 3.00V cut-off; high discharge rate shortens battery life
5	Cycle life	500 (related to depth of discharge, temperature)
6	Thermal runaway	150°C (302°F) typical, High charge promotes thermal runaway
7	Cost	~\$350 per kWh (Source: RWTH, Aachen)
8	Applications	Medical devices, industrial, electric powertrain, EVs (Tesla)
9	Comments	Shares similarities with Li-cobalt. Serves as Energy Cell.

[Table 3.4 Lithium Nickel Cobalt Aluminum Oxide \[16\]](#)

6) Lithium Titanate (Li₄Ti₅O₁₂) [16]

Positive Electrode (Cathode): lithium manganese oxide (LiMn₂O₄)

Negative Electrode (Anode): Lithium Titanate (Li₄Ti₅O₁₂)

Batteries with lithium titanate anodes have been known since the 1980s. Li-titanate replaces the graphite in the anode of a typical lithium-ion battery and the material forms into a spinel structure. The cathode can be lithium manganese oxide or NMC. Li-titanate has a nominal cell voltage of 2.40V, can be fast charged and delivers a high discharge current of 10C, or 10 times the rated capacity. The cycle count is said to be higher than that of a regular Li-ion. Li-titanate is safe, has excellent low-temperature discharge characteristics and obtains a capacity of 80 percent at –30°C (–

22°F).

No SEI film formation and no lithium plating when fast charging and charging at low temperature. Thermal stability under high temperature is also better. At only 65Wh/kg, the specific energy is low, rivalling that of NiCd. Li-titanate charges to 2.80V/cell, and the end of discharge is 1.80V/cell.

Lithium Titanate Can be lithium manganese oxide or NMC; Li4Ti5O12 (titanate) anode Short form: LTO or Li-titanate Commercially available since about 2008.		
Sr. No.	Parameter	Details
1	Voltages	2.40V nominal; typical operating range 1.8–2.85V/cell
2	Specific energy (capacity)	50–80Wh/kg
3	Charge (C-rate)	1C typical; 5C maximum, charges to 2.85V
4	Discharge (C-rate)	10C possible, 30C 5s pulse; 1.80V cut-off on LCO/LTO
5	Cycle life	3,000–7,000
6	Thermal runaway	One of safest Li-ion batteries
7	Cost	~\$1,005 per kWh (Source: RWTH, Aachen)
8	Applications	UPS, electric powertrain (Mitsubishi i-MiEV, Honda Fit EV), solar-powered street lighting
9	Comments	Long life, fast charge, wide temperature range but low specific energy and expensive. Among safest Li-ion batteries.

[Table 3.5 Lithium Titanate \[16\]](#)

[16] Figure No-3.5 below compares the specific energy of lead-, nickel- and lithium-based systems. While Li-aluminium (NCA) is the clear winner by storing more capacity than other systems, this only applies to specific energy. In terms of specific power and thermal stability, Li-manganese (LMO) and Li-phosphate (LFP) are superior. Li-titanate (LTO) may have low capacity but this chemistry outlives most other batteries in terms of life span and also has the best cold temperature performance. Moving towards the electric powertrain, safety and life span will gain dominance over capacity. (LCO stands for Li-cobalt, the original Li-ion.)

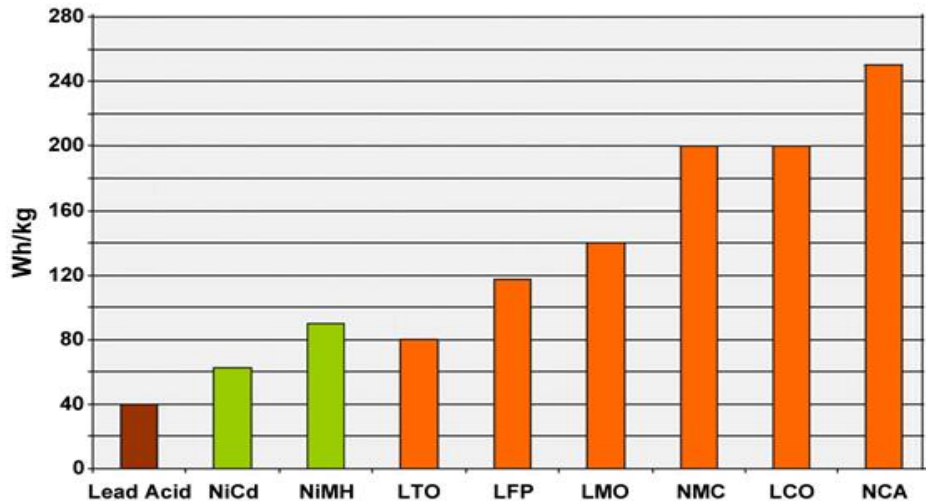

[Figure 3.5 Energy Densities of Li-ion Battery Chemistries \[16\]](#)

3.2.2 Why Lithium Batteries are taking over Market?

We referred to several options in the previous Section-3.2.1. Yet, Lithium-Ion Batteries are more into preference days now. Hence, the question arises “Why?” In the following section, you will be able to understand that, “why Lithium-Ions are more preferred over other elements”.

As we already know that Elements have Physical and Chemical Properties. Also, that we are availing Technologies for Economy based society. So, to make our services accessible to all the classes of societies, we have to come up with economically affordable Solution of Technology. On analysing modern market demands and ways of Technological Development along with delivering good quality, it is important to consider all the Technical and Economic aspects of manufacturing to lead the market and future. So in this topic, you will go through Chemical, Physical and Economical analysis of Elements.

Please refer to the following topics on Chemical, Physical and Economical analysis of the elements.

3.2.2.1 Chemical and Physical Properties of Element:

To study Chemical and Physical properties of Elements used to constitute Cathode and Anode it is recommendable to have a look at periodic table. Both are equally important to be analysed to achieve better cell

Now, as per our summary in 3.2.1, we use Elements following Elements to constitute Cathodes and Anodes.

- Cathode Elements: Nickel, Lead, Lithium
- Anode Elements: Cadmium, Vanadium, Titanium, Zirconium, Nickel, Chromium, Cobalt, and Ferrous, Carbon, etc. (All of them may be absolute or Alloys and/ or Oxides)

From studying Periodic Table, it is found that element lighter in weight yet with more electrons in its conduction band can be the most effective solution for manufacturing cell for EVs. Lithium has Atomic Mass 6 and Atomic Number 3. Hence, it has 2s valance electron, making its valency 1. This makes it best possible choice in nature. This is why Lithium Batteries are so popular in markets from both physical and chemical aspects.

3.2.2.2 Economical Details of Elements used

Costing of Material used in synthesizing a cell depends on availability of Elements on Earth's Crust. As a matter of fact, we humans with our available technologies cannot extract materials from below certain depth on Earth. The deepest known excavation to bring minerals out of the Earth crust is located in Russia, named Kola Peninsula Bore Hole. Depth of Kola Borehole is about 6.8 miles. There is no other deeper manmade excavation exist till date in the world in the known records.

Thus, based on this fact we have following data available to classify materials available in Earth's Crust.

Availability of Elements in Earth Crust used to manufacture Rechargeable Cells		
Sr. No.	Name	Percentage in earth Crust
1	Silicon	27%
2	Aluminum	8.0%
3	Iron	6.3%
4	Titanium	0.66%
5	Carbon	0.18%
6	Manganese	0.11%
7	Phosphorus	0.099%
8	Sulphur	0.042%
9	Vanadium	0.019%
10	Chromium	0.014%
11	Zirconium	0.013%
12	Nickel	0.009%
13	Cobalt	0.003%
14	Lithium	0.0017%
15	Lead	0.001%
16	Cadmium	0.000015%

Table 3.6 Available Minerals in Earth Crust in % [17]

[17] As you can see in the table above, Lithium is 0.0017% in the Earth's Crust and 25th abundant element. This is why Lithium is one of the most economical choices to make as Cathode Element. This is how price of Lithium-Ion batteries in general is less than 200\$/ kWh approximately depending on technology and region. As per some official data from surveyors like Bloomberg Finance, it is expected that the prices to go lower than 73\$/ kWh by 2030 as shown in Figure No-3.6.

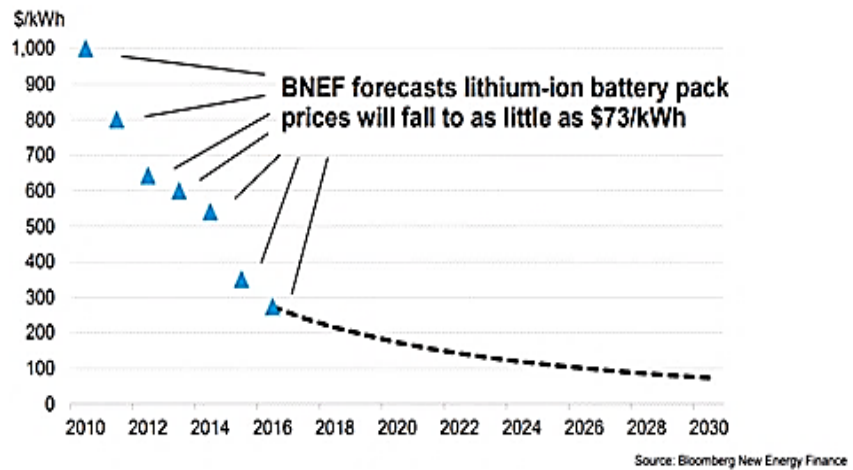

Figure 3.6 Average Price in USD/ kWh for Li-ion Batteries [18]

But, as we saw previously, that Absolute Lithium is used as Cathode in only NON-Rechargeable batteries. But, for rechargeable batteries, intercalated electrodes are used. For this purpose we use metals like Manganese, Ferrous, Cobalt, Nickel, Aluminium, etc. But for the anode we use Elements such as Graphite, Titanium or Silicon or mix of Silicon and Graphite. In this regards followings are the cheaper options available for manufacturing intercalated electrodes.

In cost aspect more expensive metal is Cobalt with 0.003% abundance as compared to Aluminium (8.0%), Ferrous (6.3%), Nickel (0.009%) and Manganese (0.11%). Hence, in this regards Ferrous based option would be cheaper. But, as we saw in previous section, all these combinations have their own benefits and limitations. Yet, the option with long range and more safety wins. In Chapter-6, we will discuss more in depth about Chemistry and Physics of Batteries.

3.2.3 In regards to Format and Arrangement of Cells:

Not only elemental physical properties are important to be well engineered but also physical aspect of construction of cell is equally important for production of Cost Efficient and Market point of view. In this regards, cell Geometry holds secret to success. In the following topics of this section, you will learn more about Engineering of Constructing Cell, then to use them to constitute a module and then finally a battery pack.

➤ **Cell Formats:**

- Cells are basically created in following 3 formats. Cylindrical cell, Prismatic cell and Pouch cell. All of these designs have their own merits and demerits as mentioned in the picture below.

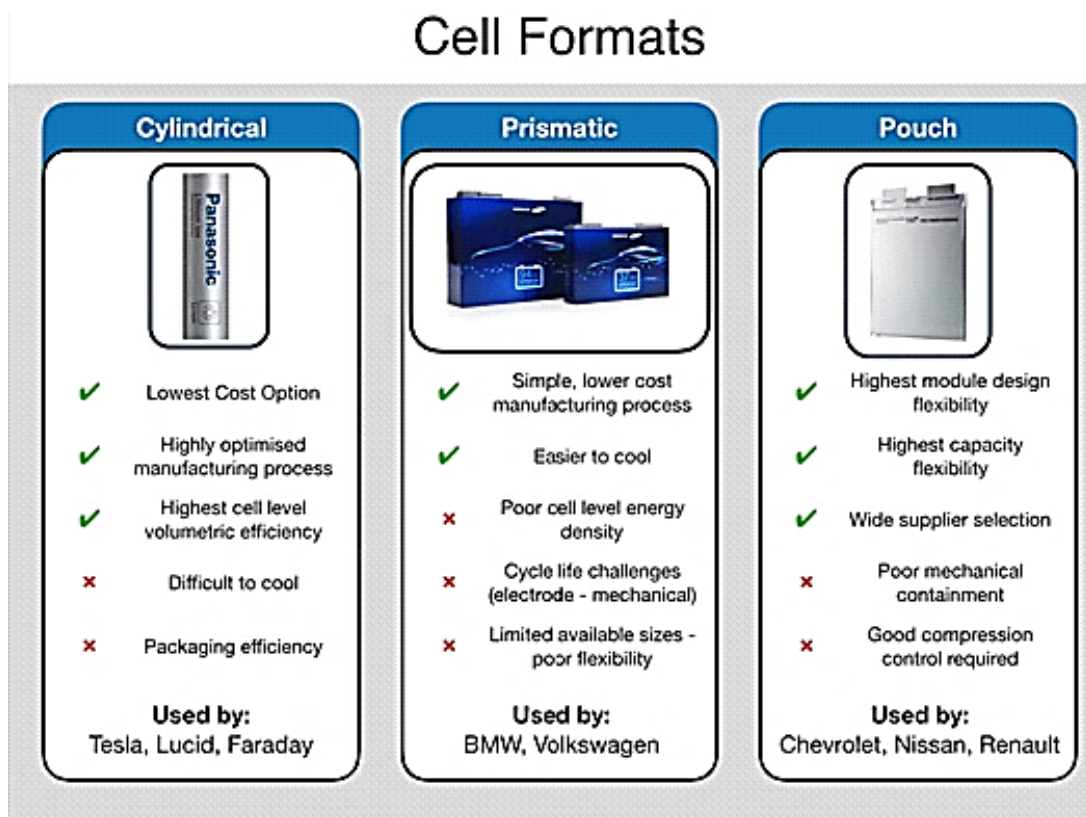

Figure 3.7 Li-ion Cell Formats [19]

- [19] As explained in the picture above Cylindrical Cell manufacturing is Production Efficient, because this format of cell has been highly mass produced by many Battery manufacturers of the world since invention of C, B, A, AA and so on cells and hence manufacturing technologies, design of cylindrical cells itself and manufacturing facilities has been perfected to best possible development level for this format. Thus, there is minimum loss of Material while manufacturing of this cell format, mainly due to advantage of the cylindrical shape. Besides for cylindrical cells, it is possible to easily develop highest possible cell's volumetric density. By removing all non-active components i.e. components that do not directly contribute in energy storage and by minimizing space that does not contribute in storing energy. This is something impossible to achieve in Prismatic and pouch cells due to Geometric reason and Cell constructional requirements. Because for example, for construction of a Prismatic Cells we perform assembly of cylindrical cells and then this cylindrically wound assembly is pressed subsequently layer by layer to best fit inside a Prismatic Shaped Aluminum case. But, yet compression is not equal at all points and this leads to some problems with life time after repeated charge and discharge cycles. But, otherwise, Prismatic shape increases area of contact that makes cooling easier for this shape. But this also has demerit with reduced volumetric energy density and increase in weight. Prismatic cell are still bigger in size as compared to Cylindrical Cell. For example, 2016 launched BMW i3 uses 94 Ah cells and 2017 launched e Golf uses 37 Ah cells. The number for used cell technology clearly explains a lot about size of each cell. This big size of Prismatic cells comes with large cell terminals too that reduces electric resistance but due to bigger size the design flexibility to manufacture battery packs of different sizes are limited. But, yet prismatic cells are very easy to stack to create a battery module, especially in our case of Electromobiles due to their cuboid shape. While, the

pouch cells uses, stacked electrodes and separators which are then inserted into an Aluminum and Polymer laminate. This is how; pouch cells offer a higher degree of design flexibility as that manufacturer can easily alter the cell capacity just by adding and removing layers to change the thickness of the cell and hence the size of each cell is easily changed. Their gravimetric density (Wh/ Kg) is competitive with cylindrical cells. However they are more to integrate into Modules and both cooling and compressing them has to be done very carefully. Yet, Cylindrical Cell still dominates both the others due to their highest volumetric (Wh/ liter) and gravimetric (Wh/ Kg) energy density combined. Also they provide excellent flexibility in designing and producing modules, except only one limitation that it is respectively hard to locate them in square shaped modules and this is a bit challenging task for car manufacturers and not for cell manufacturers. Based on industrial facts, cylindrical cells are highly optimized manufacturing option and supply chain for cells when it comes to smaller sized cells as that they are used for many small electronic equipments. Thus, it is so cheaper to have such optimized manufacturing facilities. This is why cylindrical cells have lowest manufacturing cost/ kilowatt hour. Most importantly, this is the only most stable shape possible for NCA type of Cells, and has been proven successfully by Tesla Model 3's 21700 cell. Please refer table in the beginning of this section to see pictures of all 3 types of cells.

➤ **The Module:**

- [19] Battery Modules are in other words a well stacked bunches of individual cells. Thus, a cell Module is nothing else but a battery unit. Hence, it is very important to engineer them well enough so as to maintain their volumetric energy density. Just like a cell, modules also do have so much importance of volumetric and gravimetric energy density. In fact, energy density of module is much more important than that of individual cell. In the similar manner that of a whole battery pack is much more important than an individual module. We will go into more depth about this in the next topic of this section. The major consideration for module design is as under,
 - Shape of Cell
 - Cooling arrangement
 - Weight to Wattage Ratio
 - Mechanical Stability and Strength
 - Electrical Wiring and Parameters

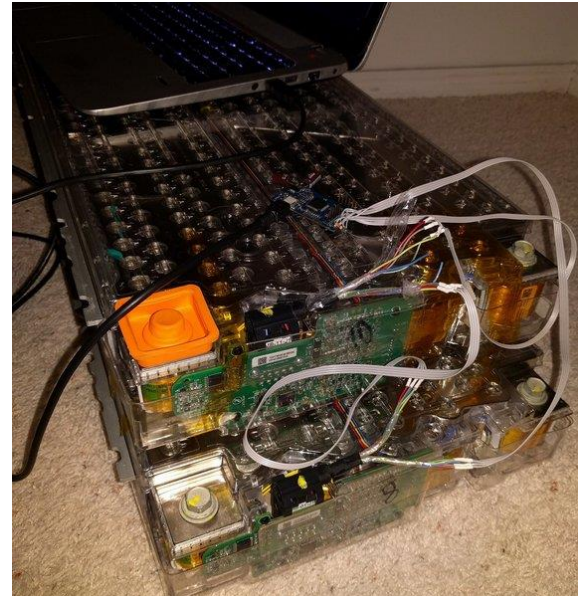
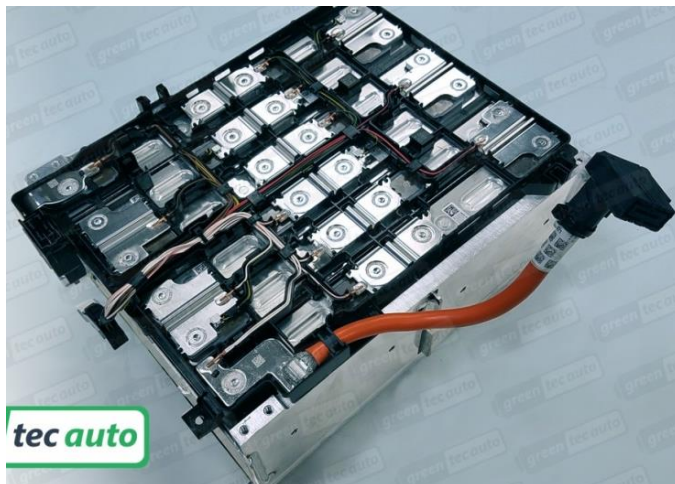

Figure 3.8 Battery Modules with BMS (a) BMW i3s, (b) Tesla Model 3 [21]

- But, not all company provide similar module design, please consider following images of BMW i3 and Tesla Model S/ X module design.
- Followings are the units that a Module comprises of:
 - Mechanical Frames
 - LV Bus Bar
 - Cooling Interface
 - Sensing Harness
- Followings are advantages of employing Battery Modules:
 - Ease of Manufacture
 - Safety in manufacturing {Due to lower Module Voltage}
 - Safety in failure/ Crash
 - Serviceability
 - Cost reduction in manufacturing versatile car models of different capacities and designs

➤ **The Battery Pack:**

- [19] In previous topic we looked into the detail of that why we use The Cell modules. In this section we will look into more details abbot importance of Battery Pack. Just to give basic explanation, Battery Packs are nothing more than just an assembly of individual modules/Batteries. A Battery Pack is device that can be actively controlled by Battery Management System for following reasons,
 - To maximize performance
 - To ensure safe operation
 - To prevent long term output performance capability degradation

- Followings are the measures strictly ensured for designing a Battery Pack,
 - Pack to cell weight ratio
 - Gravimetric and Volumetric Energy Density of Battery Pack
 - Torsional and Impact Strength of the frame provided reasonable weight
 - Efficient Cooling of pack
 - Fire Suppression in case of Cell Failure or Accidental situation

- Following are the units that a Battery pack mainly consists of:
 - Mechanical main frame to house mechanical frames of individual Batteries (Modules)
 - HV Bus Bars to connect to LV Bus Bars of each Module
 - Cooling Routing to support each individual cooling interface of modules
 - BMS consists of a CPU that ensures performance and safety of each individual battery pack which is fed by each individual sensing harness of modules
 - Main fuse to disengage battery pack in fatal failure condition of any sort
 - Individual fuses to prevent system from outputting excessive current
 - Contactor to engage and disengage battery pack from remainder of vehicle
 - Input and Output connectors to electrically and thermally connect the battery pack to remainder of the vehicle
 - Fire suppression arrangement such as Mica Sheets between each module compartments and Metallic Sheet barrier between pack and passenger compartment

- Tests:

Standard Test conducted on a Battery pack design are,

 - Pack Thermal system test
 - Crash test

3.2.4 Cooling Methods for Batteries:

[19] There are 3 common battery thermal management methods used for EVs these days: (AVID TECHNOLOGY)

- Convection to air either passively or forced

- Cooling by flooding the battery with dielectric oil which is then pumped out to a heat exchanger system

- Cooling by circulation of water based coolant through cooling passages within the battery structure

Following table shows typical cooling system in more detail that is implemented by various EV manufacturers worldwide. Yet, it's concluded that fluid based cooling is more efficient rather than passive or forced air cooling.

Sr. No.	Make & Model	Active/Passive Cooling	Coolant	Battery
1	2016 Nissan LEAF SV (100% EV)	Passive (forced air convection)	Air	30kWh lithium-ion battery; 107 mile range
2	Nissan e-NV200 (concept commercial van; 100% EV)	Active (draw air from the vehicle's climate control system and channel the air over the battery cells)	Air	-
3	2016 GM Volt (hybrid)	Active	Liquid	18.4kWh compact power lithium-ion cells in the T-shaped battery pack; all electric range 53 miles
4	Tesla Model S (100% EV)	Active	Glycol-based coolant (50% Sierra Glycol solution, 50% water)	70 kWh or 85 kWh microprocessor controlled, cylindrical lithium ion cells dubbed 18650s (248 ~ 287 mile range)
5	2016 Ford Focus Electric (all electric)	Active	Liquid	23 kWh liquid-cooled, lithium-ion battery; 76 mile range
6	BMW i3 (all electric)	Active	Direct refrigerant cooling (no extra installation in vehicle, use of existing A/C system)	22 kWh; 81 miles per charge; 150 mile total range per charge with the BMW i3 with range extender (BMW is offering a gasoline range extender engine as an option)

Table 3.7 Coolant Strategies of Different manufacturers along with their Battery Pack Details [22]

4 Survey about Charging Stations in Europe





Charging an EV in Europe differs by country. [3] Some European countries primarily use 1-phase connections to the grid, while other countries are almost exclusively using a 3-phase connection. Besides that charging compatibility of a car also depends on particular car model. Yet in general, charging facility across Europe can be summarized as followings.



Figure 4.1 Charging Facility Map Across Europe [23]

As you can see in charging map above for Europe that comprises all types of public chargers available. There are total of approximately 1045 public Charging Stations available across the Europe as per surveyors, all of them have some numbers of chargers available.

In Europe, we do not have all types of charging facilities available as per European standards. Thus, in the followings are the types of Charging Cables used in Europe and based on these charging cables Charging Points aka Charging Sockets are provided.

Slow & Fast Charging			
AC connector type	Typical Power Ratings	Approx. range per hour charging**	Features
Type 1 	3.7kW 7kW (230 V)	12.5 miles 25 miles	<ul style="list-style-type: none"> • 5-pins • Standard US socket • No locking mechanism • Single phase only • Remark: Too few in Europe
Type 2 	3.7kW 7kW 22kW (three-phase)* (400V)	12.5 miles 25 miles 75 miles	<ul style="list-style-type: none"> • 7-pins • Standard European socket • Inbuilt locking mechanism • Can carry three phase power
Rapid Charging			
DC connector type	Typical Power Ratings	Approx. range per 30 mins charging*	Features
CHAdeMO 	50kW*	75 miles	<ul style="list-style-type: none"> • Original DC connector • Most common in the UK
Combined Charging System (CCS) 	50kW 150kW** 350kW***	75 miles 225 miles 525 miles	<ul style="list-style-type: none"> • High power • Neat arrangement with 2 x 'Type 2' pins • Likely to become most popular DC standard
Type 2/ Supercharger 	130kW	180 miles	<ul style="list-style-type: none"> • Only Tesla Superchargers provide DC via a Type 2 connector • Charge rate "throttles" to protect battery • Does not charge consistently at 130kW as a result

[Table 4.1 Different Types of Chargers Used for EVs \[24\]](#)

As you can read in above table, there are 5 charging arrangements possible for EVs. Yet, problem is that all charging skims are not compatible with the models of all make. For example Tesla Model S cannot support CHAdeMO type charger. For this it needs Supercharger. This means that for each car model customer need specific type of charging socket. This makes the facility tedious for both service provider and customer. The smarter solution would be to standardize charging facility and for this purpose, Governments all over the world must come up together with standard global solutions so that services across the globe can be provided with much ease and also can be cost effective due to standardization. By now fast charging station manufacturers are implementing dual- or even triple-charging protocol support in 1 apparatus. But, surely this can be further simplified.

[54] The goal of all manufacturers is fast charging, yet their equipments are incompatible due to difference of constructional design or little parametric difference among each of them and thus these complexities can create a lot of challenges for both service provider and customer. Because, by using incompatible methods, electric car owners face a choice like the old VHS-Beta battle in the VCR world. But where a consumer could afford to throw away a Beta VCR, it's harder to do that with a \$30,000 to \$100,000 charging station or \$30,000 to \$100,000 car. The fragmentation on the part of automakers clearly says they aren't working together on a common approach to fast charging.

The future scope of improvement for charging facilities for EVs in Europe is as follows,

- Developing Standardized System for Fast Charging of EVs in Europe and if possible then also for Global level

- Expanding Network to increase Accessibility in remote areas

5 Performance Analysis of Electric Cars

In this chapter you are going to learn more about performance analysis of Electric Cars. The Goal of this analysis is to find out,

- I. Amount of energy consumed by different cars to cover same amount of distance and based on assumption that all 3 of the cars are subjected to same Traffic and Weather conditions throughout travel. Thus I came up with factual assumptions for my calculations as mentioned in the following sections of this chapter.
- II. To find out whether a car can cover the distance based on provided climatic conditions and based on its technical specifications (Including various declared efficiencies by the manufacturer) or not.

Note, that for entire calculations all units are considered and converted in MKS (SI) except that in the end of calculations we have converted result of power from joule to kWh.

5.1 Assumptions:

The analysis is basically a mathematically simulated reality that constitutes of 4 major factors as mentioned below:

- I. Finite Geographical Route Condition:

The route is, From CTU in Prague to Technical University in Brno.

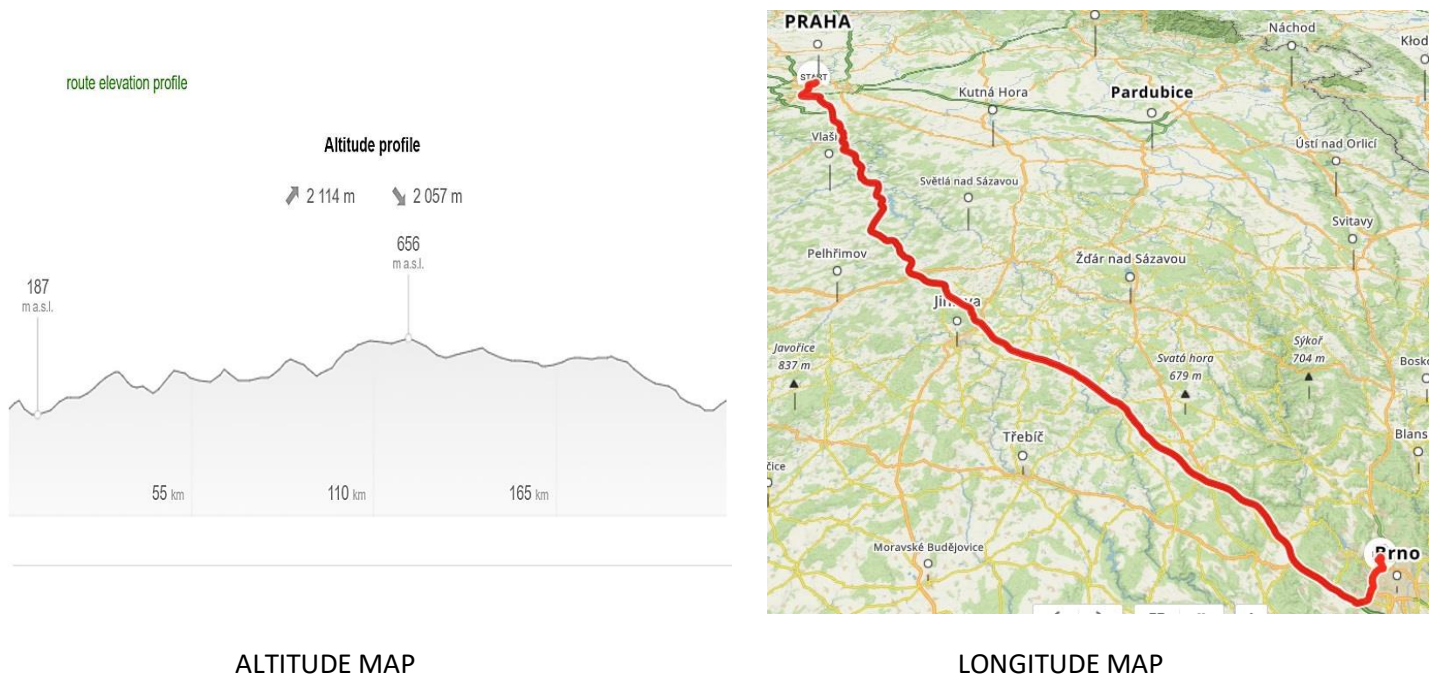

ALTITUDE MAP

LONGITUDE MAP

Figure 5.1 (a) Altitudinal Map and (b) Longitudinal Map Between Prague and Brno [25]

These maps are from Mappy.cz, where one can find altitude detail of the route for approximately 101 points throughout the travel duration inclusive of location of departure and destination. This is how I have considered all 101 points for my calculation.

II. Number of Acceleration and Retardation:

For ease of calculation along with being realistic about road condition and traffic, I have considered 3 occasions of acceleration and 4 occasions of deceleration.

III. Weather Data of the day with assumption that the weather condition would remain the same throughout the travel.

Abstract about the parameters acquired for calculations are as under:

Weather Parameters (Assumed to be fixed)		
Average Height from Sea Level	360	meter
Gravitational Acceleration	9.8	m / s ²
Average Humidity	63%	
Average Air Pressure	1.024	Bar
Air Density (ρ)	0.444	kg / m ³
Air Temperature	19	°C
Total Time for both Cars to cover Distance	Seconds	Hours
	8970.91	2.49
Average Wind Speed (V_w)	1.39	m/s

Mechanical Specs of Cars							
Name of Cars	Mass of Vehicle	Co-efficient of Rolling Resistance	Aero-dynamic Drag	Height	Width	Frontal Area	Radius of Wheel + Tire (rd)
	m (kg)	Crr	Cx	a (m)	b (m)	A (m ²)	m
Nissan Leaf e+	1731	0.015	0.28	1.50	1.80	2.70	0.32
Tesla Model 3	1847	0.015	0.13	1.40	1.9	2.66	0.33
VW e-Golf	1540	0.015	0.27	1.45	1.80	2.61	0.32

Table 5.1 Weather and car Constants [27], [28], [29], [30], [32], [33]

IV. Car Models Considered for Calculation:

- a) Nissan Leaf
- b) Tesla Model 3
- c) Volkswagen e-Golf

5.2 Approach to perform Analysis:

To perform this analysis, I have performed calculations mainly in 4 parts,

- I. Dynamics Analysis
 - a) Road Dynamics Analysis
 - b) Car Dynamics Analysis
- II. Energy Calculation While Phases
 - a) Energy Consumed while Acceleration Phase
 - b) Energy Consumed while Constant Speed Phase
 - c) Energy Consumed while Breaking Phase
- III. Efficiency Based Energy Calculation

There are basically 6 efficiencies,

$\eta_{\text{drivetrain}}$	Efficiency of Mechanical Power Transmission
$\eta_{\text{bat_char}}$	Charging Time Efficiency of Battery
$\eta_{\text{bat_dischar}}$	Discharging Time Efficiency of Battery
η_{motor}	Motor Efficiency
$\eta_{\text{converter}}$	Power Converter Efficiency that includes both Rectifier and Inverter
Recuperation Efficiency	Recuperation Efficiency is another Efficiency of a car model that depends on the Electrical and Mechanical Design of the car. It stands for amount of Energy that can be recovered from Car from being lost due Mechanical losses while Mechanical Breaking.
Driving Efficiency	This stands for assumption of amount of energy lost due to traffic and other inside utilities of car (i.e. Electronics in the car). Here remainder is the loss and the percentage shows the energy that could be used. I have considered it to be 70% for all cars for ease of calculation. This means that 30% Energy is lost due to Mechanical Breaking and Utilities of Car.

[Table 5.2 Efficiency and Driving Efficiency](#)

In this step I have calculated Energy for all 3 phases by multiplying them with their relevant efficiencies depending on the stage. Because of the fact that 100% Power from Batteries does not reach the wheels. This is due to efficiencies of various components including that of Batteries. Thus, we have to calculate Energy that can be put to attain work as a result of efficiencies and that is explained in each phase in the followings.

- i. Energy Consumed while Acceleration Phase

Because we only spend energy while this phase and so for this Phase, I have considered four efficiencies $\eta_{\text{drivetrain}}$ and $\eta_{\text{bat_dischar}}$, η_{motor} , $\eta_{\text{converter}}$ and Driving Efficiency.

- ii. Energy Consumed while Constant Speed Phase

Because we only spend energy while this phase and so for this Phase, I have considered four efficiencies $\eta_{\text{drivetrain}}$ and $\eta_{\text{bat_dischar}}$, η_{motor} , $\eta_{\text{converter}}$ and Driving Efficiency.

iii. Energy Consumed while Deceleration Phase

Because we also receive energy while regenerative braking and so for this Phase, I have considered four efficiencies $\eta_{drivetrain}$ and η_{bat_char} , η_{motor} and $\eta_{converter}$.

iv. Power Statistic:

Here, you can see amount of power (kWh) consumed by an EV to cover the total distance and also amount of remaining power (kWh) in the battery pack.

Besides these 4 steps, I have adhered to a set variant and that is to fix 2 different Top Speeds for both Variants, to find out that in what variant the car consumes more energy. So in this approach variant-1 is where the top speed is limited to 120 kmph and in variant-2 the top speed is limited to 90 kmph.

5.3 Equations used to perform Calculation:

In this section you will go through all Equations for each stage for you to see mathematical analysis order for entire calculation.

I. Part-1: Dynamics Analysis

i. Road Dynamics Analysis

Here, Dynamics Analysis of road is done with the approach that we measure Geographical Condition of a given segment of land area with respect to Earth Sea Level. Meaning that if Geographic analysis is to be performed on a road that is located at a given Geographic Location on Earth then we need to find out Longitude and Altitude of that particular area as that these 2 vital mathematical components affect dynamic performance of a car travelling on it.

Thus, to mathematically depict these components as one we need to make use of Tangential Component to reflect actual Geographical Condition of road throughout the route of travel. Hence, Mathematical analysis can be done as followings,

Here, I have done my best to create realistic mathematical depiction of the actual geographical conditions,

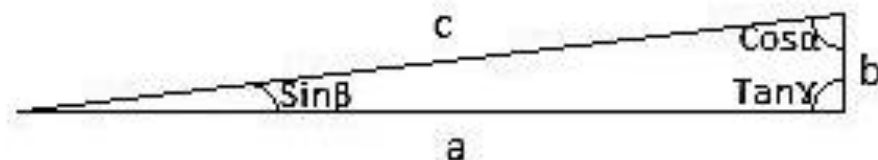

[Figure 5.2 Pythagorean Depiction of Road](#)

Where,

$\text{Cos}\alpha = a/c = \text{Longitudinal Component of the Road} = \text{Length of given section}$

$\text{Sin}\beta = b/c = \text{Vertical Component of the Road} = \text{Height of the given section from Sea Level.}$

$\text{Tan}\gamma = b/a = \text{Geographic Condition of Actual Road.}$

This logic is further used to find out $F_{RR} = \text{Force due to Rolling Resistance}$ (i.e. Horizontal Component) and $F_{vc} = \text{Force Due to Vertical Climb}$ (i.e. Vertical Component).

But, note that in my calculations, I have not made use of equation of Tangent, because our analysis does not go through this approach. We only need to know F_{RR} and F_{vc} . The only other thing that is required to be found is length c because that is actual length of the road that a driver is driving up on. To find this I have followed simplest law of Pythagoras. As mentioned on the next page,

$$c = \sqrt{a^2 + b^2}$$

..... [Equation 5.1](#)

ii. Car Dynamics:

Here, I have calculated basics of car such as RPS at particular instance on the route and also time taken by a car to cover particular distance at any point on the route. Besides that I have also assumed number of occasions for acceleration and deceleration and also the time during each of these occasions. These informations are important to carry out Performance analysis. As that Performance Analysis can be carried out only if several basic details of road, car and climate are known.

The next part in this step is to find out time that any of the cars would take with prefixed assumed speed for a particular span of distance. Thus, by using simplest equation of velocity we can find time (seconds, all units in MKS as mentioned in the beginning of the chapter).

$$t = \frac{d}{v}$$

..... [Equation 5.2](#)

Where,

v = velocity of a car

d = distance covered by a car

t = time consumed by a car

Another important thing to find out about a car is angular velocity (revolutions/ s) of its tires and this is done by using equation,

$$RPS = \frac{v}{rd}$$

..... [Equation 5.3](#)

Where,

v = velocity of a car

RPS = revolution per seconds

rd = radius of wheel + tire

Apart from these all, any car on any road basically go through 4 types of forces,

F_{RR} = Force due to Rolling Resistance (i.e. Horizontal Component) and

$F_{ACC/R}$ = Force while Acceleration/ Retardation

F_{VC} = Force Due to Vertical Climb (i.e. Vertical Component).

F_{ad} = Force due to Aerodynamics

Later, I have depicted these forces in terms of energy in next step, i.e. Part -2.

Last but not least, I have also considered constants such as C_{rr} and C_x , A and m_c . These constants are explained in the following section.

I have assumed 3 occasions of Acceleration and 4 occasions of Deceleration.

II. Part-2: Energy Calculation While Phases

In this part I have calculated Energy consumed by the car throughout 3 basic phases.

Phase-1 = Energy during Acceleration Phase

Phase-2 = Energy during Constant Speed Phase

Phase-3 = Energy during Breaking Phase

Please have a look in the following section to find out energy calculation while all 3 phases.

i. Phase-1,

Energy Calculation during Acceleration Phase,

This phase comprises of 4 states. Thus, total Energy Consumed by the car during this Phase is the sum of all 4 states as mentioned below.

$$E_{Phase-1} = E_{rr1} + E_{vc1} + E_{acc1} + E_{ad1}$$

... .. [Equation 5.4](#)

E_{rr} = Energy consumed due to Rolling Resistance

E_{vc} = Energy consumed during Vertical Climb

E_{acc} = Energy consumed to overcome Inertia of the car while acceleration

E_{ad} = Energy consumed due to Aerodynamic Drag

State-1, Energy consumed due to Rolling Resistance (E_{rr1}):

In this State the energy is consumed by the car because that Car has its own Mass and thus weight. Thus, when Car travels from one location to another location, the machine of the car has to spend energy to overcome mass of the car and also the friction between Tire and the Road. This is represented as co-efficient of Rolling Resistance C_{rr} . Together all these opposing forces are called Rolling Resistance. For this purpose of calculation I considered cosine component of the forces, because cosine component is parallel to horizon and thus it is associated to rolling resistance. This can be mathematically depicted in the following equation:

$$E_{rr1} = \int_0^d (m_c * g * C_{rr} * \cos\alpha) * ds = \int_0^t (m_c * g * C_{rr} * \cos\alpha) * v * dt$$

$$E_{rr1} = (m_c * g * C_{rr} * \cos\alpha) * \frac{1}{a} * \left[\frac{v_2^2 - v_1^2}{2} \right]$$

... .. [Equation 5.5](#)

Where,

m_c = Mass of Car

s = Distance

g = Gravitational Acceleration

C_{rr} = Co-efficient of Rolling Resistance

$\cos\alpha$ = Horizontal Component of the Road

$\sin\beta$ = Vertical Component of the Road

a = Acceleration, b = Retardation

V_2 = Final Velocity

V_1 = Initial Velocity

A = Cross-sectional Area of the car

C_x = Coefficient of Aerodynamic Drag of a Car

T_1 = Initial Time

T_2 = Final Time

State-2, Energy consumed during Vertical Climb (E_{vc1}):

When a car travels through a road uphill or downhill, the amount of energy spent by a car varies depending up on gradient of the slope. When a car moves downhill, it spends less energy as compared to when it goes uphill. This force effect is in vertical plane and has directly to do with altitude difference of two consequent points. Thus, it is associated with Sine component and this can be depicted as under,

$$E_{vc1} = \int_0^d (m_c * g * \sin\beta) * ds = \int_0^t (m_c * g * \sin\beta) * v * dt$$

$$E_{vc1} = (m_c * g * \sin\beta) * \frac{1}{a} * \left[\frac{v_2^2 - v_1^2}{2} \right]$$

... .. [Equation 5.6](#)

State-3, Energy consumed to overcome Inertia of the car while acceleration (E_{acc1}):

Initially car has no velocity and thus it has maximum Inertia, for this reason the machine of the car has to spend energy to overcome Inertia of the car.

$$E_{acc1} = \int_0^d (m_c) * a * ds = \int_0^t (m_c) * a * v * dt$$

$$E_{acc1} = (m_c) \left[\frac{v_2^2 - v_1^2}{2} \right]$$

... .. [Equation 5.7](#)

State-4, Energy consumed due to Aerodynamic Drag (E_{ad1}):

As the car start to run, because of the cross-sectional area of the car, it's always opposed by air. This phenomenon is called as Aero-Dynamic Drag. This can be mathematically depicted as under,

$$E_{ad1} = \int_0^d \left(\frac{1}{2} * \rho * C_x * A * v^2 \right) * ds = \int_0^t \left(\frac{1}{2} * \rho * C_x * A * v^2 \right) * v * dt$$

$$E_{ad1} = \left(\frac{1}{2} * \rho * C_x * A \right) * \frac{1}{a} * \left[\frac{v_2^4 - v_1^4}{2} \right]$$

... .. [Equation 5.8](#)

ii. Phase-2,

Energy Calculation during Constant Speed Phase,

$$E_{Phase-2} = E_{rr2} + E_{vc2} + E_{acc2} + E_{ad2}$$

... .. [Equation 5.9](#)

State-1, Energy consumed due to Rolling Resistance (E_{rr2}):

As that we have constant speed of the car, the energy calculation is from formula below,

$$E_{rr2} = (m_c * g * C_{rr} * \cos\alpha) * v_2 * t_2$$

... .. [Equation 5.10](#)

State-2, Energy consumed during Vertical Climb (E_{vc2}):

$$E_{vc2} = (m_c * g * \sin\beta) * v_2 * t_2$$

... .. [Equation 5.11](#)

State-3, Energy consumed to overcome Inertia of the car while acceleration (E_{acc2}):

$$E_{acc2} = 0$$

... .. [Equation 5.12](#)

State-4, Energy consumed due to Aerodynamic Drag (E_{ad2}):

$$E_{ad2} = \left(\frac{1}{2} * \rho * C_x * A\right) * v_2^3 * t_2$$

... .. [Equation 5.13](#)

iii. Phase-3,

Energy Calculation during Deceleration Phase,

$$E_{Phase-3} = E_{rr3} + E_{vc3} + E_{rb3} + E_{ad3}$$

... .. [Equation 5.14](#)

State-1, Energy consumed due to Rolling Resistance (E_{rr3}):

$$E_{rr3} = \int_0^d (m_c * g * C_{rr} * \cos\alpha) * ds = \int_0^t (m_c * g * C_{rr} * \cos\alpha) * v * dt$$

$$E_{rr3} = (m_c * g * C_{rr} * \cos\alpha) * \frac{1}{b} * \left[\frac{v_2^2 - v_1^2}{2}\right]$$

... .. [Equation 5.15](#)

State-2, Energy consumed during Vertical Climb (E_{vc1}):

$$E_{vc3} = \int_0^d (m_c * g * \sin\beta) * ds = \int_0^t (m_c * g * \sin\beta) * v * dt$$

$$E_{vc3} = (m_c * g * \sin\beta) * \frac{1}{b} * \left[\frac{v_2^2 - v_1^2}{2}\right]$$

... .. [Equation 5.16](#)

State-3, Energy gained by means of regenerative braking (E_{acc1}):

$$E_{rb3} = \int_0^d (m_c) * a * ds = \int_0^t (m_c) * a * v * dt$$

$$E_{acc3} = (m_c) * \left[\frac{v_2^2 - v_1^2}{2}\right] * \text{Recuperation Efficiency}$$

... .. [Equation 5.17](#)

Most of the times results of the calculation for this state are negative in number, this is because of regenerative braking that converts mechanical energy of the car into Electrical Energy and thus, we end up gaining energy while braking and this energy is then sent back into the battery pack.

A thing to note about this state is that, we don't end up gaining 100% energy at the end of this state. There are some limitations to amount of power converted into Electrical Energy and that is due to loss in heat, loss in mechanical transmission and also loss in the converter and Electric Motors themselves. Thus, altogether total efficiency of the system depends up on Engineering of a Car.

State-4, Energy consumed due to Aerodynamic Drag (E_{ad1}):

$$E_{ad3} = \int_0^d \left(\frac{1}{2} * \rho * C_x * A * v^2\right) * ds = \int_0^t \left(\frac{1}{2} * \rho * C_x * A * v^2\right) * v * dt$$

$$E_{ad3} = \left(\frac{1}{2} * \rho * C_x * A\right) * \frac{1}{b} * \left[\frac{v_2^4 - v_1^4}{2}\right]$$

... .. Equation 5.18

III. Part-3: Efficiency Based Energy Calculation:

Power Transmitted from Battery Pack to all the way till the surface of contact between road and tire is NEVER 100%. There are so many losses due to limitations in efficiencies of parts of a car. Such as, Efficiencies of Battery Pack, Converter, Motor and Mechanical Transmission and Recuperation Efficiency.

In following table you can go through all considered Efficiencies at Top Speed 90 kmph:

NISSAN LEAF		VW e-Golf		TESLA MODEL 3	
$\eta_{drivetrain}$	97%	$\eta_{drivetrain}$	96%	$\eta_{drivetrain}$	97%
η_{bat_char}	96%	η_{bat_char}	93%	η_{bat_char}	97%
$\eta_{bat_dischar}$	94%	$\eta_{bat_dischar}$	91%	$\eta_{bat_dischar}$	95%
η_{motor}	93%	η_{motor}	91%	η_{motor}	95%
$\eta_{converter}$	91%	$\eta_{converter}$	91%	$\eta_{converter}$	94%

[Table 5.3 Efficiency Table at Top Speed 90 kmph \[31\], \[34\], \[35\]](#)

In following table you can go through all considered Efficiencies at Top Speed 90 kmph:

NISSAN LEAF		VW e-Golf		TESLA MODEL 3	
$\eta_{drivetrain}$	96%	$\eta_{drivetrain}$	95%	$\eta_{drivetrain}$	96%
η_{bat_char}	95%	η_{bat_char}	91%	η_{bat_char}	95%
$\eta_{bat_dischar}$	93%	$\eta_{bat_dischar}$	89%	$\eta_{bat_dischar}$	94%
η_{motor}	92%	η_{motor}	89%	η_{motor}	94%
$\eta_{converter}$	89%	$\eta_{converter}$	87%	$\eta_{converter}$	93%

[Table 5.4 Efficiency Table at Top Speed 120 kmph \[31\], \[34\], \[35\]](#)

Besides these Efficiencies as we discussed previously that Recuperation Efficiency is also one more Efficiency of car model that depends on the Electrical and Mechanical Design of the car and thus for Nissan Leaf=77%, Tesla Model 3=88% and for VW e-Golf=73%. This efficiency has been considered as a part of Energy Calculation in Deceleration Phase, because that is the calculation stage where this efficiency must be considered in the system of equation so as to maintain precision of calculation.

The last key factor for Energy Calculation is Driving Efficiency. This stands for assumption that amount of energy lost due to traffic and other inside utilities of car (i.e. Electronics in the car). Here remainder is the loss and the percentage shows the energy that could be used. I have considered it to be 70%. This means that 30% Energy is lost due to Mechanical Breaking and Utilities of Car.

Following are the Equation that I applied for Efficiency Based Energy Calculation for all 3 Phases:

i. Efficiency Based Energy Calculation During Acceleration Phase:

In this Phase we mostly spend Energy and thus the Efficiency Based Energy Equation would be as under,

$$E_{\eta_{acc}} = \frac{E_{Phase-1}}{\eta_{bat_dischar} * \eta_{drivetrain} * \eta_{motor} * \eta_{converter} * \text{Driving Efficiency}}$$

[... .. Equation 5.19](#)

ii. Efficiency Based Energy Calculation During Constant Speed Phase:

In this Phase as well, we mostly spend Energy and thus the Efficiency Based Energy Equation would be as under,

$$E_{\eta_{con}} = \frac{E_{Phase-2}}{\eta_{bat_dischar} * \eta_{drivetrain} * \eta_{motor} * \eta_{converter} * \text{Driving Efficiency}}$$

[... .. Equation 5.20](#)

iii. Efficiency Based Energy Calculation During Deceleration Phase:

In this Phase we regain energy due to regenerative breaking and thus the Efficiency Based Energy Equation would be as under.

$$E_{\eta_{decel}} = E_{Phase-1} * \eta_{bat_char} * \eta_{drivetrain} * \eta_{motor} * \eta_{converter}$$

[... .. Equation 5.21](#)

IV. Part-4: Power Statistic:

In this part, obtained Energies from all 3 phases are added and then converted into power to find out total power consumption of the car at the end of the travel.

5.4 Results of the analysis:

Result for all analysis not only depends on hardware or software of a system but it also depends on test conditions. For test purpose we have considered 2 Top Speeds of the Cars under test. Conditions provided that we have considered all set up to be the same. Only things that change are Cars and Top Speed. Having done these all, I obtained result as following.

Variant: 1 Top Speed 90 kmph:

Car	Consumption (kWh)	Remaining (kWh)
Nissan Leaf	39.88	22.12
Tesla Model 3	33.48	41.52
VW e-Golf	38.38	-6.38

[Table 5.5 Energy Statistics at Top Speed 90 kmph](#)

Variant: 2 Top Speed 120 kmph:

Car	Consumption (kWh)	Remaining (kWh)
Nissan Leaf	51.30	10.70
Tesla Model 3	38.91	36.09
VW e-Golf	52.02	-20.02

[Table 5.6 Energy Statistics at Top Speed 120 kmph](#)

At the end of this analysis, it was found that VW e-Golf cannot cover distance from CVUT at Prague to technical University in Brno for both speed variants. In case of Top Speed 90 kmph it goes up to 179.59 km and in case of Top Speed 120 kmph it goes up to 132.50 km. Thus, it can be concluded that a Charging Station must be provided at Ostředek Village. Another suggestible option is that at every 100 km there should be a charging station.

6 Survey of Future Trends of Electro-mobility

There are so many scopes for new researches and evolution for Electromobile technologies. Having a brief look in the past, one can easily observe evolution in Conventional Fuel based automobile Technology. We can observe that Hydrocarbon based automobiles took almost 100 years to get to the point of almost perfection that we see now in automobile industries across the globe. To perfect the technology in regards to high efficiency of Engines, Aerodynamics, Ergonomics, Various types of fuel compatibility and so on. Of course for Electromobiles, we do not need to start from scratch, but yet there are so many scopes to develop Batteries and other Electrical Circuit components so as to improve performance of Electromobiles. This is what we talked in Technological Aspect. But, besides technology, at the same time we have a lot of improvements possibly achieve in processes for manufacturing them so as to make them more cost effective, affordable and sustainable. We can also establish laws in Governments of Countries worldwide, so that when these vehicles or their parts are worn out; they can be effectively recycled, so that the market prices of raw materials that are not so ample in amount on Earth Crust can yet be affordably accessible through recycling and not just get wasted. Companies like Maxwell technologies are doing just that for improving manufacturing technologies. Besides there also may new rising industries with revolutionary ideas, such as Enevate, Sila Nano Technologies and Enovix are developing new cost effective technologies for Batteries. Besides many universities worldwide are also performing active participations in all possible ways. Please, refer to the following sections to learn more in detail.

6.1 Dry Electrode Manufacturing Process Technology:

[36] As we introduced this technology in Chapter-3, this is an advanced manufacturing procedure and this must not be misunderstood by solid state batteries, as that solid state battery is a whole different concept based on solid electrolyte that we will discuss in further section of this chapter. Dry Electrode Technology is aka Dry Battery Electrode and abbreviated as DBE. Classical slurry based wet coating technology has drawbacks such as solvent toxicity, reactivity between electrode material and solvent and unwanted changes of physicochemical properties of coated electrodes. Maxwell's proprietary solvent-free coating technology resolves such issues.

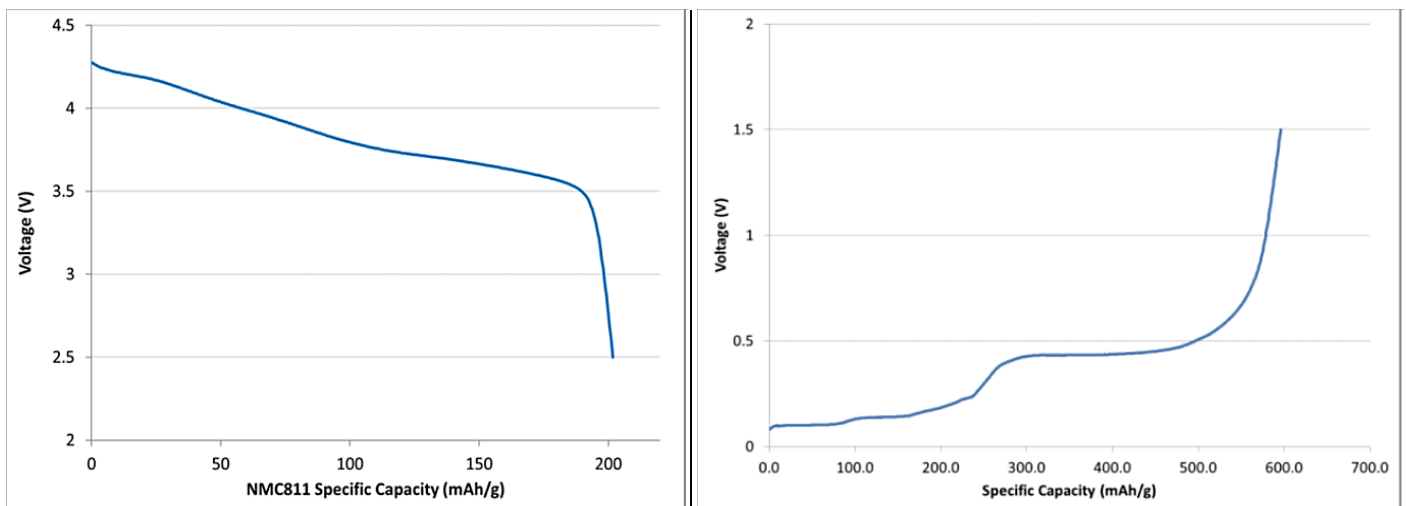

[Figure 6.1 Discharge voltage profile of dry coated NMC811 cathode \(top\) and dry coated silicon-graphite composite anode \(bottom\) half-cell. \[36\]](#)

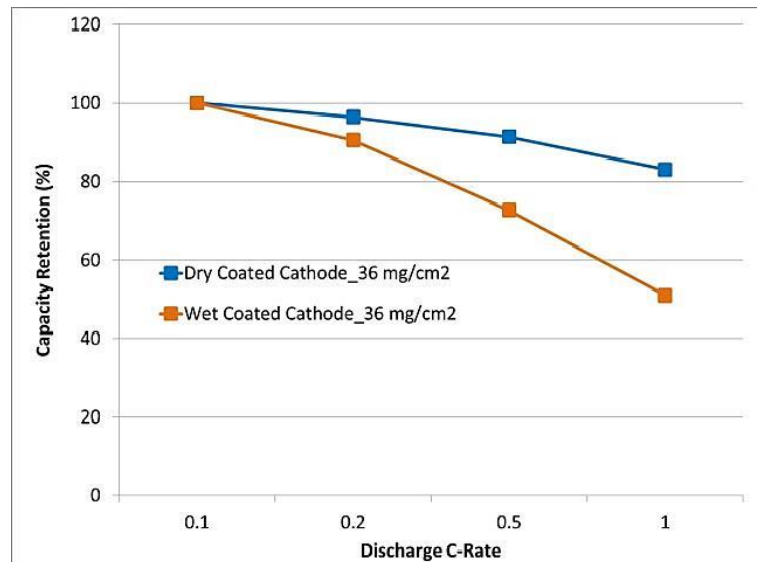

Figure 6.2 Discharge rate performance of dry coated NMC111/graphite full-cell in comparison to wet coated NMC111/graphite full-cell. Electrode loading is 5mAh/cm². Cut-off voltage was 4.2V and 2.8V for charge and discharge, respectively. [36]

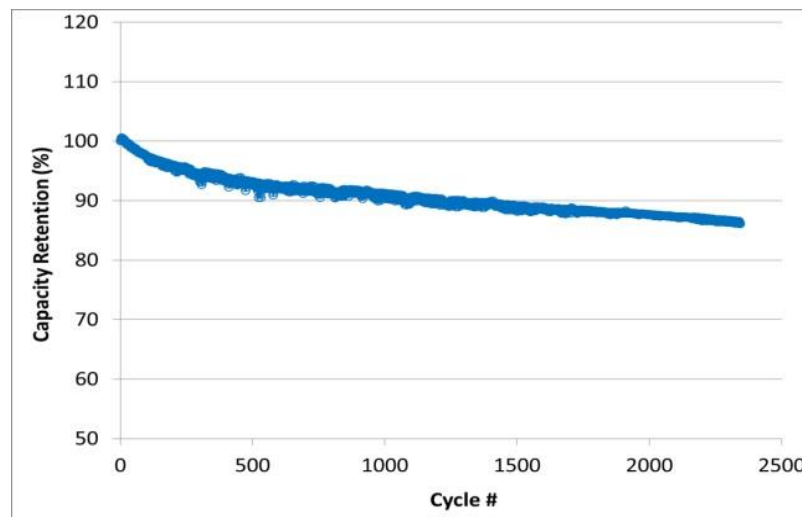

Figure 6.3 Cycle performance of dry coated NMC/graphite electrode in a prototype pouch cell at constant current 0.5C charge/1C discharge: Electrode loading- 4mAh/cm². Cut-off voltage was 4.2V and 2.7V for charge and discharge, respectively. [36]

These results suggest that dry coated electrodes exhibit lower particle-to-particle contact resistance and charge transfer impedance, likely due to a uniform network of interconnects between binder and active material particles. [36] Additionally, prolonged cycle life performance of dry coated electrodes in small prototype pouch cells and large format pouch cells, $\geq 10\text{Ah}$, is under evaluation.

➤ Advantage: [36]

- Offers significantly high loading
- It is possible to produce a thick electrode using this technology that capable for high energy density cells without compromising physical properties and electrochemical performance.
- Maxwell's DBE provides better discharge rate than those of wet coated electrode.
- Provides good scalability
- Robust Performance even for longer electrochemical cycles
- Excellent long-term electrochemical cycle performance
- Reduced amount of emission of gases like CO₂, during manufacturing process of Electrodes.
- No drying of electrode required

6.2 Future Batteries:

Future of Humanity depends on batteries, until something entirely different show up. This is why many Institutions and Industries across the Globe are working to enhance battery technology and to make it more economical that would be made of Earth Crust Abundant elements rather than rare Earth Elements. Also, new Technologies like Nano-Technology are capable enough to enhance Existing options into more engineered perfection. Following sections goes in to further detail about each available well known option.

6.2.1 Graphene:

[37] Graphene is also called to be Wonder Material of the world. It was found accidentally by Professor Andre Geim and Dr. Konstantin Novoselov. Graphene is much more similar at its molecular construction to Graphite. It's a two Dimensional lattice of Graphite. In simpler words it's just a two dimensional sheet of Carbon, that does not have any intermolecular bond in 3rd dimension at all. Generally, these 2D lattices are rolled in to a cylindrical form. This is called as a Graphene Tube. According to many sources Graphene is 6 times stronger than conventional Steel and it has Electric Conductivity much higher than that on Silver. But at the same time it is lighter than air. It has opposite thermal property as compared to all conventional elements on Earth that it expands on Cooling and Contracts on Heating.

[37] Haegyeom Kim, Kyu-Young Park, Jihyun Hong and Kisuk Kang have invented an all Graphene Cell that has bridged difference between super Capacitor and Conventional Battery Cell. An all Graphene battery that operates based on fast surface-reactions in both electrodes, thus delivering a remarkably high power density of $6,450 \text{ W kg}^{-1}$ total electrodes while also retaining a high energy density of 225 Wh kg^{-1} total electrode which is comparable to that of conventional lithium ion battery. The performance and operating mechanism of all-Graphene-battery resemble those of both super capacitors and batteries, thereby blurring the conventional distinction between super capacitors and batteries. This work demonstrates that the energy storage system made with carbonaceous materials in both the anode and cathode are promising alternative energy-storage devices. In the following Figure No-6.4 you will go through some vital characteristic graphs and images of this technology. [37]

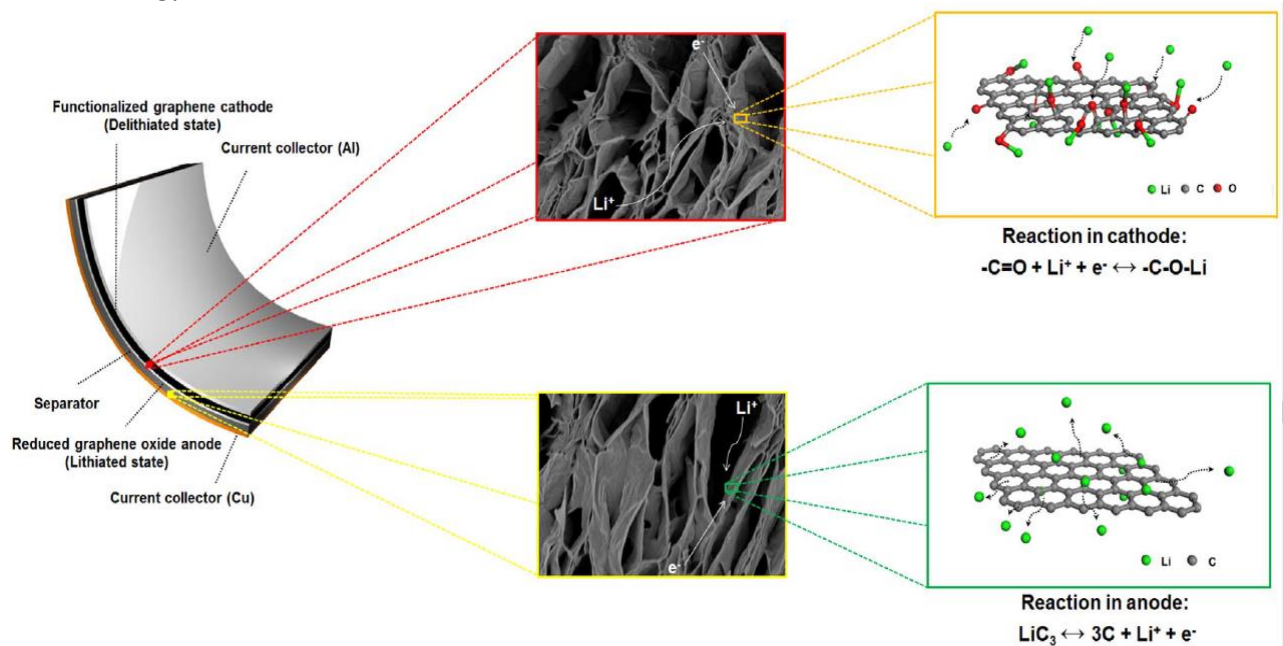

Figure 6.4 Graphene Nano-Structure [37]

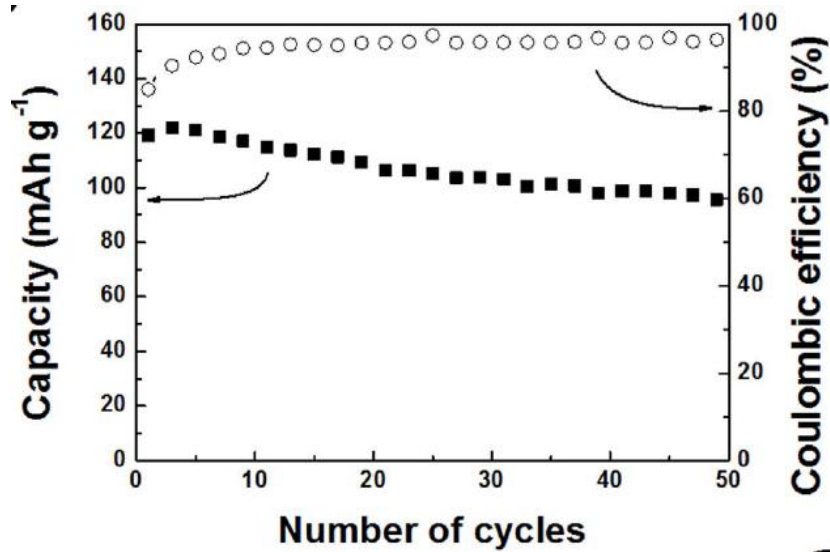

Figure 6.5 Cycles vs Capacity Graph [37]

6.2.2 Silicon Nano-Technology:

[38] Silicon is the most earth abundant element. On the earth Crust there is about 27% Silicon. It has 4 Valance electrons, just like Carbon and this makes it replaceable to carbon in many applications. For example application of Silicon in medical industries is well known. Electrical and electronics in so exception either. After many researches it has been found that in widely used Graphite based Anodes, it takes about 6 Carbon atoms to hold 1 Lithium ion. While, due to its physical properties, 1 Silicon atom can hold about 4.4 Lithium Ions, if calculated mathematically. Besides it has very low toxicity. Silicon has high theoretical specific capacity of 4212 mAh g⁻¹, higher safety and stability than graphite. However, Silicon anodes have property to expand as much as 300% to 400% of its volume, due to charge and discharge cycles. This ends up with physical deformation of anode itself. This reduces its electrical conductivity duty deteriorating ion storage capacity. In the following topics you will learn more about diverse Si-Nano-Structures, Si- metal Nano composites and Si-C Nano-composites.

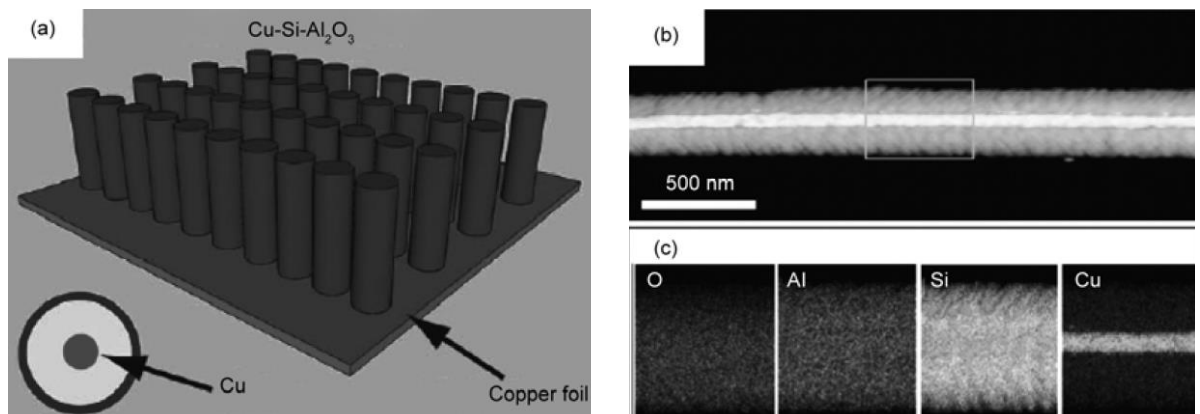

Figure 6.6 (a) Schematic; (b) Annual dark-field TEM image and (c) corresponding EDX elemental mappings of O, Al, Si, and Cu for the Cu-Si-Al₂O₃ nanocables; [38]

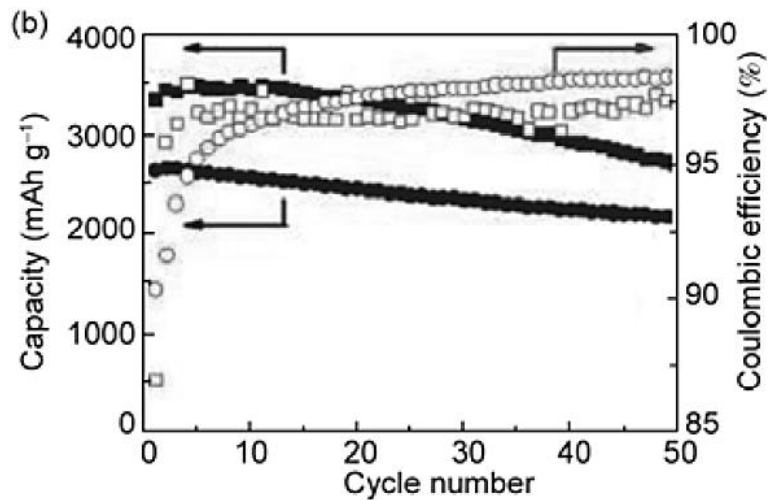

Figure 6.7 cycle performances at a rate of 0.05 and 0.2 C (square: 0.05 C, circle: 0.2 C) of a vertically aligned Si NT array. Reprinted with permission from. Copyright (2010) American Chemical Society. [38]

6.2.3 Solid Electrolyte Batteries

Anode: Lithium or Sodium

Cathode: Air or S₈, or Fe³⁺/Fe²⁺ (aq.)

[39] Solid Electrolytes are compact in size and have high volumetric energy density. Following figure gives examples of various types of Solid electrolytes and a graph of their Electrochemical Stability vs. Conductivity at room temperature.

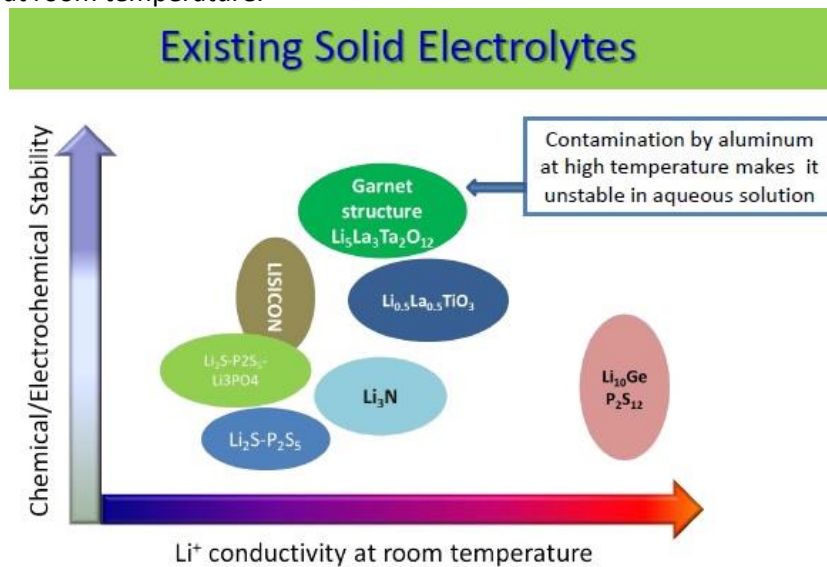

Figure 6.8 Existing Solid Electrolytes [39]

As seen in the Figure No-6.8 above, general Structure Electrolytes are electrochemically stable with a large window than commercial LiSiCON membrane and are not sensitive to water as sulphides, so they are promising separators for flow through batteries using aqueous solutions.

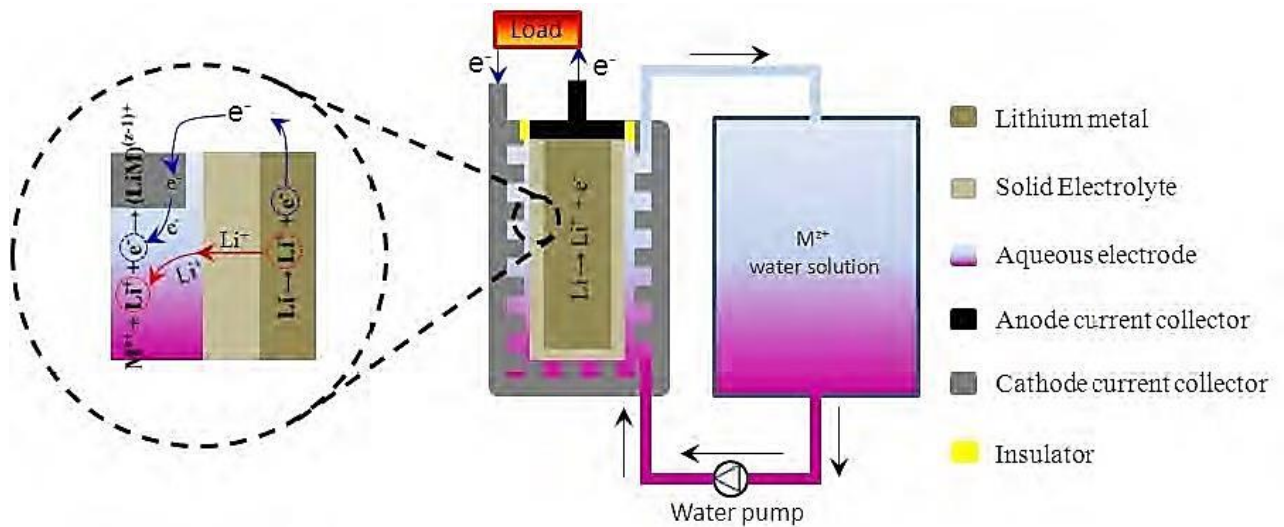

Figure 6.9 An Alkali-Metal/Aqueous Cathode Cell with Solid Electrolyte [39]

Above Figure No-6.9 shows schematic diagram of Solid Electrolyte battery with solid anode and liquid cathode. This arrangement can be an excellent possibility for EVs.

➤ Why solid state cell? [39]

- Because in conventional liquid electrolyte battery followings are demerits
 - We have significant capacity decrease due to Solid Lithium solution in Cathode and loss in SEI layer at Anode.
 - Voltage limited by E_g (gap voltage) of Carbonate Electrolyte.
 - Problem of Dendrites.
- Advantages: [39]
 - All solid-state cell would simplify and lighten packaging
 - Sulphides offer large E_g and $\sigma_{Li} > 10^{-3} \text{ S/cm}$
- Disadvantages: [39]
 - Insertion compounds change volume on cycling, so cycle life of solid/solid interfaces is problematic

➤ What are Advantages and Disadvantages of Solid-Electrolyte Separator?

- Advantages: [39]
 - Enabling use of lithium metal anode to increase cell voltage and capacity or also allow an absolute Lithium Anode
 - Eliminating irreversible Li loss from cathode side during the first charge
 - Enabling use of liquid cathodes with higher capacity than insertion hosts
 - Would block dendrites from a lithium anode or a Li/ solid-electrolyte interface
 - Would allow alternative cathodes, e.g. air, S_8 , or $Fe^{3+}/Fe^{2+}(aq.)$ flow through
- Disadvantages: [39]
 - For an aqueous cathode, need an oxide separator:

$\sigma_{Li}(oxide) \approx 10^{-4} \text{ S/cm}$ fabricated thin and dense on a support; and not reduced by lithium.

6.2.4 Solid state Batteries

[40] Solid State batteries are a recent revolutionary research done by John Goodenough (Ph.D. Physics), University of Texas at Austin (USA) and Maria Helena Braga (Ph.D. Physics), University of Porto (Portugal). Mr John Goodenough is founding father of Lithium Ion batteries and is currently working as Professor of Mechanical Engineering and Material science at University of Texas. Both of them came up with implementation of Di-electric Glass as solid state electrolyte, there by developing a completely solid state battery where the chemical reaction is not conventional redox reaction.

Anode: Lithium or Sodium

Cathode: S_8 or other Solid

[40] This cell configuration has Anode, Cathode and Electrolyte all solid. A solid electrolyte may be Polymer, Ceramic or a composite of a Ceramic or Glass with a polymer. Gels containing a liquid electrolyte mobilized in a polymer are not considered here to be solid electrolytes.

[40] An electrolyte Li^+ has conductivity of $\sigma_{Li} > 10^{-3} S cm^{-1}$ only above $55^\circ C$ prevents a rapid charge/discharge at $20^\circ C$ with these electrolytes. Dendrite free plating on anode and cathode. Also, Electrode volume change is no longer a problem. Electro Plating of Lithium can be done reversibly on both anode and cathode. Following Figure No-6.10 gives you basic understanding and an insight on the features of this technology.

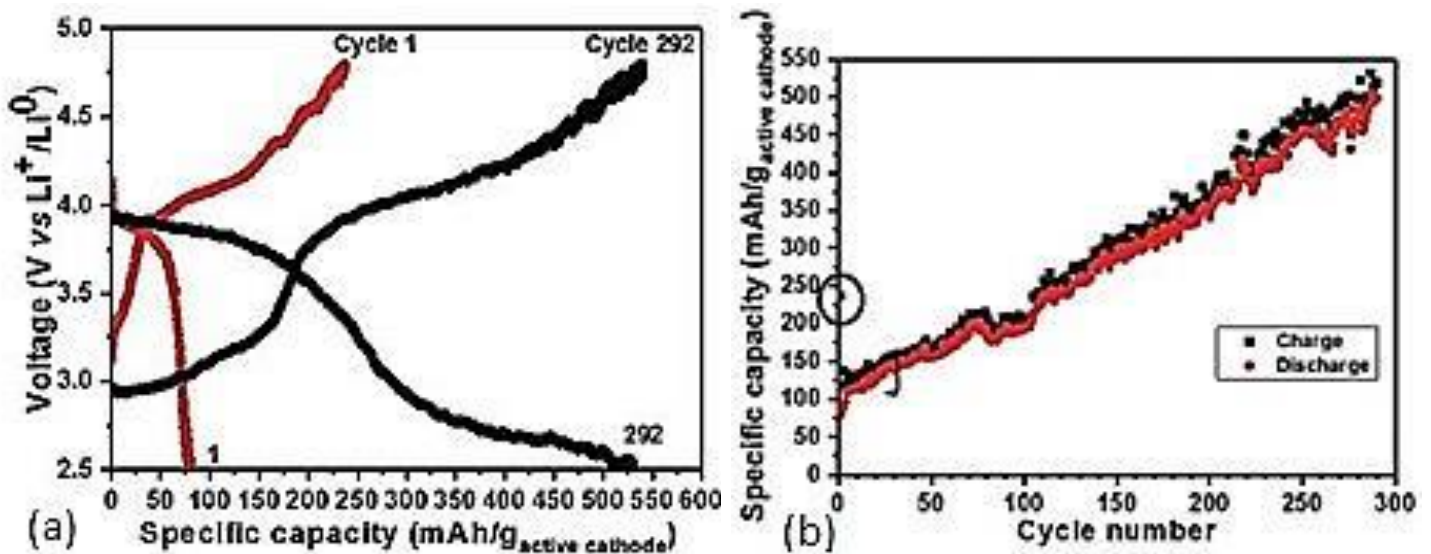

Figure 6.10 Voltage discharge of an Li/Li-glass/dielectric plasticizer + LNMO + C in Al current collector cell. (a) discharge cycles; (b) charge and discharge capacity as a function of cycle number (circle around first charge). [40]

6.3 Circuit Boost Using Ultra Capacitors: [41]

An Ultra-Capacitor as we know it is a production from Maxwell Technologies. They are just another type of Supercapacitors. Dry Electrode Manufacturing process was initially developed to produce Ultra-Capacitors. Ultra-Capacitor can give large power boost to the motor of an EV initially to provide inertial torque and there by providing fast acceleration to an EV. This is very hard to achieve for an EV utilizing only Battery pack for acceleration purpose. Besides these capacitors also are perfect power storing device at the time of regenerative braking and then while performing immediate acceleration. For such high traction purposes Ultra-Capacitors are not only robust but are also sort of protection device for battery to level down sudden tractional loading directly on Battery Pack.

6.4 Non- Contact Battery Charging for EVs:

Non-contact Battery pack charging can be implemented for EVs, that may be fixed on Public Places for charging. Some governments across the world like Government of France and USA have already implemented test plans to check feasibility of wireless charging on public roads where the roads themselves would be made up of Solar Panels protected by a sheet of robust silicon based material.

6.5 Other Technologies:

As an Alternative to Classical Li-Ion Battery Pack based BEVs, there are many innovations going on in Fuel Cell and Battery Technologies such as,

- Nano Flow Cell
- Aquion Batteries

These technologies are simple yet a big subject within themselves. So many behind the scene revolutionary results have been obtained with minimum environmental impact in various stationary and mobile applications and they also give much promising signs about future of Electric Cars. These technologies only substitute classical Batteries up to certain limit. But, the driving mechanism uses Electrical Traction Motors here as well.

Not famous enough though due to many global political implications, yet a Brand named Quant has manufactured a car model named e-Sportlimousine is one such example that gives much promising signs for future success of this Technology as soon as the world will seek alternative of Lithium Ion Batteries.

7 Comparison between Electromobiles and Hybrid Car

We have already gone through basic Engineering of EVs and have also gone through specifications of each car model for EV technology. But, for sake of technical and economical comparison, we also need to go through specifications of particular car models and basic engineering of Hybrid cars. We have already discussed basic types of Hybrids in Chapter-1. Thus, in this section we will pick one of them which is more manufactured in the market. PHEVs are the most manufactured and successful type of Hybrid cars in the market. So, let us have a look in basic design and components of PHEVs.

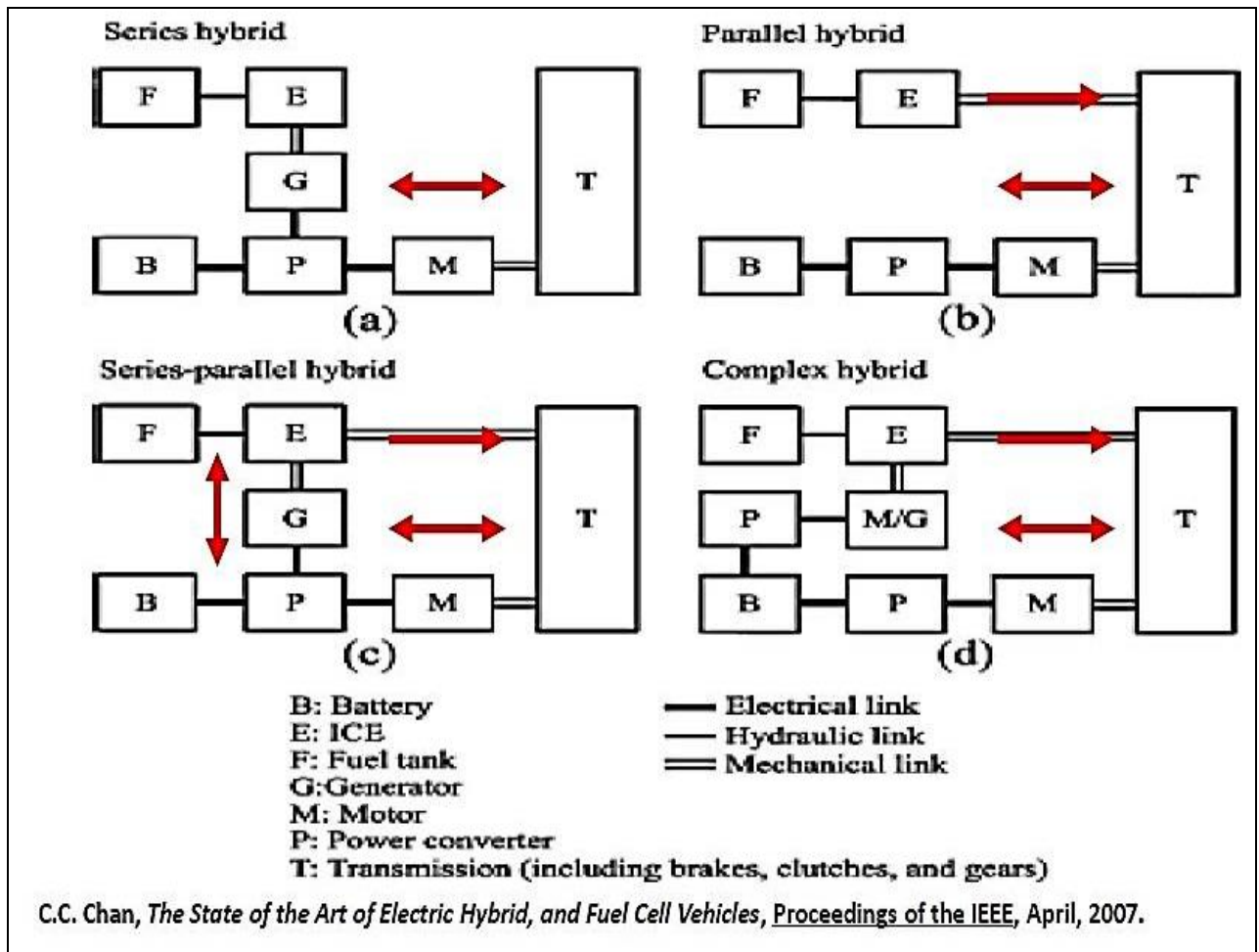



Figure 7.1 Systems Architectures of HEVs [42]

Most successful PHEVs produced in the market uses parallel or compound. Because, in series PHEVs losses are higher due to conversion from mechanical to Electrical Transformation of energy. In the followings we have considered an example of PHEV to compare with pure EV in regards to Technical and Economic Analysis.

Sr. No.	COMPARISON BETWEEN			
	KIA OPTIMA		TESLA MODEL 3	
2				
3	Type	PHEV	Type	EV
4	Price USD	35390	Price USD	41450
5	0-100 kmph	8.7	0-100 kmph	4.6
6	Top Speed kmph	120	Top Speed (kmph)	233
7	Total Driving Range (km)	980	Total Driving Range (km)	445
8	All Electric Range (Km)	0-46	All Electric Range (km)	445
9	All Electric Km/Kwh (roundup from MPGe)	4.9	All Electric Km/Kwh (roundup from MPGe)	6
10	Total Km/Kwh (roundup from MPGe)	1.9	Total Km/Kwh (roundup from MPGe)	6
11	Consumption, kWh/100km	52.63	Consumption, kWh/100km	16.67
12	Tank Capacity in Liter (kWh)	54.888 (532.33 kWh)	Battery Capacity (kWh)	75
13	Hybrid Analogy	2.0 liter, Inline 4 Full Parallel Hybrid System	Hybrid Analogy	N/A
14	Torque, 2.0-Liter Engine	Torque, 2.0-Liter Engine	Torque, 2.0-Liter Engine	N/A
15	Electric Motor	Interior-Permanent Magnet Synchronous Motor	Electric Motor	Three phase, four pole AC induction motor with copper rotor, liquid cool with VFD
16	2.0-Liter Engine (kW)	114	2.0-Liter Engine (kW)	N/A
17	Electric Motor (kW)	50	Electric Motor (kW)	258
18	Combined (kW)	150	Combined (kW)	N/A
19	Torque, Combined (Nm)	374	Torque (Nm)	527
20	Weight (kg)	1525	Weight (kg)	1847

[Table 7.1 Comparison Table for Tesla Model 3 and KIA Optima \[43\], \[44\], \[45\], \[46\], \[47\]](#)

Conventional cars have about 1000 active components and about total of 20000 parts altogether. But, Electric cars have about 200 active components on an average and about 3000 parts altogether. [48] Not sticking to numbers so strongly because of variations in manufacturing of car from manufacturer to manufacturer. But, even though it is simply understandable that Hybrid or a Plug in Hybrid would surely have much more active components and parts as compared to absolutely Electrical Car.

For simplest understanding we can say that an average PHEV with good Electrical and Fuel based range would have many fixed and rotary components in them. This means manufacturing a PHEV would be much more complex task for manufacturer as compared to that of manufacturing an EV. Besides, the production queue would be much space occupying and needs more men and robotic power. Besides, so many molders and other system engineering are required to produce such a complex car. Programming codes required for Automation of PHEVs is much longer and complex as compared to pure fuel or electric car. Not to mention that for HEVs or PHEVs there is a lot of engineering design and precision is required to attain maximum optimized output due to that there are many rotary parts in PHEVs and HEVs. EVs have only 1 major rotary component, i.e. Motor. Except motor, there are negligible amounts of rotary parts in an average absolute EV. Thus, it requires less maintenance and maintenance is easy. Also, manufacturing of an EV for a manufacturer would be much easier and cost effective in above discussed regards.

Besides EVs are far more energy efficient as compared to fuel and hybrid cars as seen in the table previously in this chapter. Average PHEV can travel up to 1.9 km for 1 kWh and that of an average pure EV can travel up to 6 km for 1 kWh. However there are 2 major drawbacks of EV over Hybrid. EVs use Lithium based redox cell chemistry up to date in domestic cars worldwide. Specific and volumetric Energy density for Li cells is significantly very low to that of Gas, Petrol or diesel based Hybrid. Most Hybrids including PHEV, uses electrical component just to recover energy loss while driving, especially in cities and to improve overall efficiency of the vehicles in certain drive modes.

8 Conclusion

2. Survey of Electric Car, Conclusion:

After enough analysis of obtained data, it was found that best traction drive for Electromobiles is Induction Motor also known as Asynchronous Motor due to its property such as high torque capacity and easier speed control. This type of motor, involves simplest Drive train, because most of the speed control is achieved by means of Electronic Control Drive.

In the following Table and Graph you can go through the best buy option based on best technical features and in regards to your requirement.

Sr No.	Model Name	Parameters					
		Type	Price	Range	Top Speed	0-100	Energy Consumption
			USD	km	km/h	Seconds	kWh/ 100km
1	KIA Optima	PHEV	35390	980	120	8.7	52
2	Smart EQ Fortwo	Pure EV	23900	145	145	11.5	12
3	Audi e Tron		81800	400	200	5.5	22
4	VW e-Golf		46046	128	140	10.4	16
5	Jaguar I-Pace		69500	470	200	4.5	22
6	BMW i3s		44450	246	149	7.2	16
7	Nissan Leaf S+		36550	363	193	7.3	17
8	Tesla Model 3		41450	445	233	4.6	16
9	Tesla Model S		69750	434	249	2.4	17

[Table 8.1 Basic Specification Table for All Surveyed Models](#)

From numbers in the above table it is clear that “Smart EQ fortwo” has lowest price, but has low performance as well. But, it can be a good purchase for daily life city use. But as opposed to other EVs and even PHEV, the statistics are not impressive, yet it has very good energy efficiency as compared to “KIA Optima” PHEV. But, if someone can afford reasonable amount of money then Tesla Model 3 becomes best purchase, because it has reasonable price, longer range and higher speed and acceleration. These specifications make Tesla Model 3 usable not only for city, but also for driving on Highways to travel between longer destinations.

But, more detailed comparison between more relevant parameters is given in following graphs, where you can clearly see which car makes best buy.

We live in the world where energy is everything, thus here first consideration for comparison is Driving Range vs. Energy Consumption.

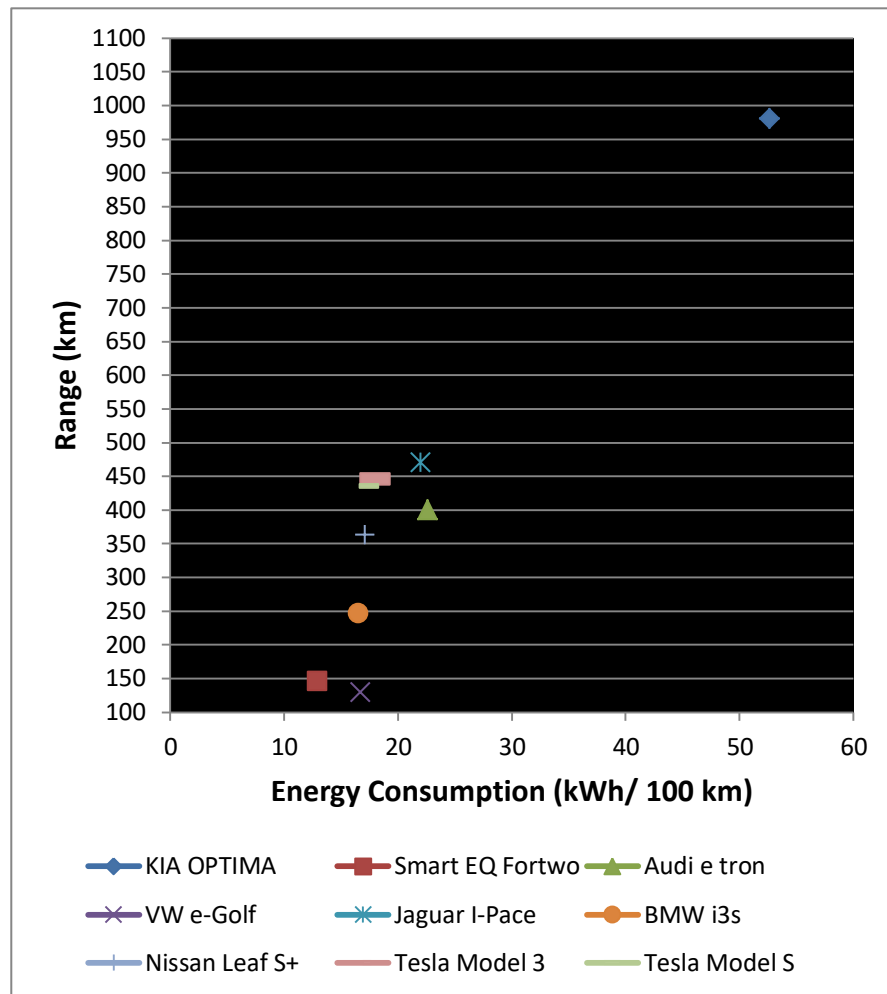
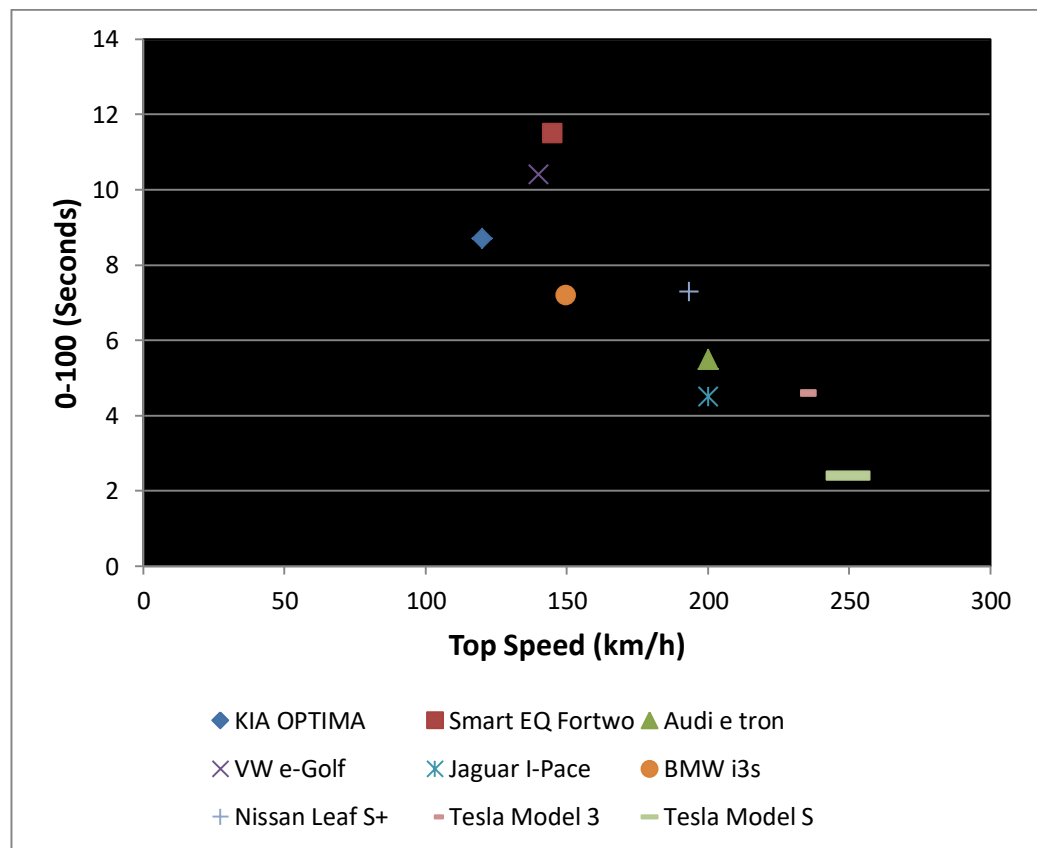

Figure 8.1 Range and Energy Consumption Graph for different Electric Car Models

As it can be observed in the above graph, of Course KIA Optima provides highest driving range, but it comes with Highest Energy consumption as well. Thus, it's clear that longer range should not be the only consideration for a smart customer, rather reasonable range with high energy performance should be prime consideration for a smart customer because it not only takes care of economy but also ecology for an individual. Thus, from the above graph seemingly Jaguar i-Pace becomes winner but it's not true. Refer to the table where Jaguar i-Pace consumes 22 kWh/ 100 km and runs up to 470 km while the second performer in the graph is Tesla Model 3 with consumption of 16.67 kWh/ 100 and runs up to 445 km in a single charge. Thus, it's clear that the best performance is delivered by Tesla Model 3 for this category of comparison.

The next sensible comparison would be to compare Speed vs. Acceleration as shown in the graph below.



[Figure 8.2 Acceleration vs. Top Speed Graph of Different Electric Cars](#)

As it can be seen on the graph above, Tesla Model S makes clear winner at first sight. As that it stands with Maximum Speed of 249 km/h with 0-100 acceleration in 2.4 seconds. But considering price of the car, Tesla Model 3 again makes winner with 233 km/h in 4.6 seconds.

Thus from these parameters we conclude that Tesla Model 3 becomes best purchase in regards to many features like Energy Consumption, Speed and so on. But yet, it's not so much convincing while looking at the range of Tesla Model 3 as opposed to that of KIA Optima PHEV. Thus I decided to make economic based analysis in the 7th section of this chapter so as to clearly see that how much one can save by purchasing what car and what would be the payback period for invested money. This comparison is so vital to understand whether it would be sensible to prefer pure EV aka Electromobile over a PHEV or not! Please refer to chapter 2 for more information on this and to conclude best buy.

3. Batteries, Conclusion:

It is clear that battery technology is evolving very rapidly, since the return of Electrical Cars in the market. As per all the studies in the Chapter-2, Chapter-3 and Chapter-6 of this paper and also from other papers, it is easily concluded that world does not have any better option than Lithium Ion batteries for now and more likely may not be for few decades. Yet it's much expected that there are more elements as well that can be cheaper and yet a good option. For example Sodium (Na) and

Magnesium (Mg) are such elements. The battery technologies that we have in present years are also promising enough to compete with performance of other technologies such as conventional fuel.

4. Charging Stations, Conclusion:

Thus it can be concluded that if the following major remarks be worked on then it can help develop good infrastructure for all over Europe at very reasonable investment rather than random brand oriented individual charging infrastructure.

- Developing Standardized System for Fast Charging of EVs in Europe and if possible then also at Global level
- Expanding Network to increase Accessibility in remote areas

5. Performance Analysis of EVs, Conclusion:

From the table of result, it can be seen that Tesla Model 3 is the best performance car in the given Geographic and Weather conditions. While, Nissan Leaf has poor performance in regards to energy consumption as compared to both Tesla Model 3 and VW e-Golf.

VW e-Golf cannot travel the whole distance in both 90 kmph and 120 kmph Top Speed variants, due to limitation of its battery capacity.

6. Survey on Future Trends in Electro-mobility, Conclusion: [56]

It can be concluded from Chapter-6 that there are so many scopes of advancements for Electromobiles in many aspects. But, moving to the existing reality and future soon to approach, many Car manufacturers are planning to launch a car with Solid State Battery. The new Fisker Inc. announced plans to build the all-electric EMotion in 2016 and it finally revealed the vehicle at the 2018 Consumer Electronics Show (CES) in Las Vegas. First, the basics: The top-tier model will have a 400-mile (643.73 km) range, a 160-mph top speed, and will cost \$129,000. Fisker said that is the price for cars with the “ultra-large battery pack,” indicating that, like rivals Tesla and Lucid Motors, it will offer several battery options. Thus, Fisker will be first to publically launch a Solid State battery car by year 2020.

7. Comparison of HEVs and PHEVs, Conclusion:

In this section of conclusion, I have used data from Chapter-7 to reflect economical comparison between Electromobile and Plug in Hybrid Vehicle to understand, if Pure Electromobiles are future and much efficient both ecologically and economically or not.

Be sure to refer to excel sheet named “Czech Economic Analysis of EV and Hybrid” to understand calculations in more detail. In the followings I have provided outline understanding, key points and results of the analysis and along with that final conclusion as well.

- Calculation of Annual Driving Cost:

In the following calculation, one can clearly see that how cheap an EV is to drive as compared to a Hybrid car.

- Facts, Czech Market 2018:
 - Price of Petrol: 31 Kč/ Litre [52]
 - Price of Electricity: 4 Kč/ kWh [51] (Main advantage is High Efficiency of Electric Cars)
 - Average Czech Drives: 1609 km/ Month

- Mileage and Annual Cost of KIA Optima:
 - Mileage: 18 km/ Litre (i.e. 1.9 km/kWh)
 - Annual Cost: 32643 Kč/ year

- Mileage and Annual Cost of Tesla Model 3:
 - Mileage: 6 km/ kWh
 - Annual Cost: 12928 Kč/ year

Thus, it's clear that driving Tesla Model 3 is 2 times cheaper as compared to driving KIA Optima on annual bases as per present and much likely future market conditions. Only the Maintenance Price of Tesla is higher as compared to that of KIA Optima.

➤ But, what about higher price of Tesla Model 3 as compared to KIA Optima?

Here, please note that Tesla Model 3 costs more because the version we have considered is for long range. We chose long range version so as to make effective comparison between both. Thus, price is a bit higher. Standard price with standard range of Tesla Model 3 is almost same (varies by 2300 Euro in German Market. In US market, both are same price) as that of KIA Optima. (These cars are not available in Czech Republic, but there are many Teslas and KIAs in Czech Republic).

➤ Calculation of Payback Period of Tesla Model 3 as opposed to KIA Optima:

- Facts and Assumptions:
 - Yearly Cost Analysis for KIA OPTIMA: 32643 Kč
 - Yearly Cost Analysis for Tesla Model 3: 12928 Kč
 - Minimum Expected Life of Car: 10.00 Years
 - Percentage Escalation in Price of Gasoline/ Gallon in Czech Republic: 0.070%
 - Percentage Escalation in Price of Electricity/ kWh in Czech Republic: 0.01%
 - Inflation: 2.00%[53]
 - Yearly Maintenance cost KIA Optima: 11581 Kč [49]
 - Yearly Maintenance cost Tesla Model 3: 14061 Kč [50]

- Payback Period Calculation:
 - Tesla Model 3 is more expensive than KIA Optima by: 322059 Kč
 - Cost Difference after 10 years of Driving:
 - ✚ Fuel Cost of KIA Optima is higher than that of Tesla Model 3 by: 370385 Kč
 - ✚ Maintenance Cost of Tesla Model 3 is higher than that of KIA Optima by: 27700 Kč
 - As mentioned in the excel sheet of Calculations, it was found that at the 10th year total Maintenance + Fuel cost of Tesla Model 3 becomes lower as compared to KIA Optima by 342685 Kč.

- Note that these results are based on the assumptions mentioned above in the beginning of this section. The assumptions are based on facts because I have all Future rates of Czech Market are assumed based on Market History of Czech Republic up to year 2010. Besides that, as a matter of fact that Future is never same as past thus for these future rates I have considered facts such as Global Political Scenario, Future Plans for NCEs, Globally dwindling resources of Hydrocarbons and their increasing prices and so on.

- Besides that I have also made Economic Analysis of both cars in US market as well. Assumptions of rates for the calculations are based on History of US Market up to year 2010. The results show that for USA as well 10 years is the time that it needs to compensate cost difference

between Tesla Model 3 and KIA Optima, (i.e. payback period) Please refer to the Excel Sheet named as "US Economic Analysis of EV and Hybrid".

Final Conclusion:

As seen from the above Economic Analysis, it's clear that driving an Electric car can save money up to 2 times than driving a Hybrid Car even in bad weather condition. Only limitation that exists in days now is Higher Price of EVs as compared to PHEV. But, with more market stability and new technologies prices of EVs can also be expected to go low. Hybrid car majorly works on fuel and thus emission is inevitable, while EVs use Electricity that can be collected from non-conventional Energy sources and thus minimum emission while using them is ensured and their less energy consumption ensures less carbon footprint even if Electricity used comes from Thermal Power Plants. So, in this regards, Electromobiles are best Purchase.

Besides that, to be specific about both Economic and Technical Performance analysis comparison scenarios, we can together agree up on the fact that Tesla Model 3 is the Car Model with the best Technological and Cost Effective Design that benefits a customer in all aspects and expectations and yet it is healthy for Environment as well.

Thus finally, in General it can be concluded that driving an EV is economically and ecologically much smarter choice. This is an old technology but forgotten one and is now coming back in market and hence improvements are happening more rapidly since a decade unlike ever before. Soon we will have lighter in weight and yet more energy efficient and cheaper in price Electromobiles in the market. Electromobiles will be more eco-friendly indirectly and directly contributing to minimize atmospheric emission worldwide. These many merits are much more promising to conclude that Electromobiles make Best Purchase and much superior Technology.

Nomenclature & Acronyms

Nomenclature

Km	Kilometer
Kg	Kilogram
Wh/Kg	Watt-hour/ Kilogram
Kmph or Km/h	Kilometer per Hour
V	Volt
USD or \$	American Dollar
Kč	Czech Crown
RPM	Revolutions per Minute
Nm	Newton Meter
kW	Kilowatt
A	Ampere
kWh	Kilo Watt Hour
Hp	Horse Power
A*h or Ah	Ampere Hour
S	Seconds
bhp	British Horse Power
hrs	Hours
sX	Laplace of Impedance
R	Resistance
XL	Inductive Reactance
f	Frequency
L	Self-Inductance
Wh/L	Watt-hour per Liter
V/cell	Volt per Cell
C-rate or C	Charging Rate

°C	Degree Celsius
°F	Degree Fahrenheit
Bar	Atmospheric Pressure Unit
m / s ²	Meter/ Second Square
kg / m ³	Kilogram per Meter-cube
mAh	Mili-Ampere Hour
aq.	Aqueous
S/ cm	Siemens per Centimeter
σ _{Li}	Conductivity of Lithium ions

Acronyms

HEV	Hybrid Electric Vehicle
EVs or EV	Electric Vehicles
IC	Internal Combustion
SAE	Society of Automotive Engineers
AC	Alternating Current
DC	Direct Current
AWD	All-Wheel Drive
FWD	Forward Wheel Drive
RWD	Rear Wheel Drive
1-Φ	Single Phase
PMSM	Permanent Magnet Synchronous Motor
IPMSM	Interior Permanent Magnet Synchronous Motor
RMF	Rotating Magnetic Field
Li-ion	Lithium Ion
AAA	Battery Size
AA	Battery Size
A	Battery Size

LV	Low Voltage
HV	High Voltage
BMS	Battery Management System
LiSiCON	Lithium-ion Superionic Conductor
CPU	Central Processing Unit
CHAdEMO	Charge De Move
CTU	Czech Technical University
DBE	Dry Battery Electrode
SEI	Solid Electrolyte Interphase
VFD	Variable Frequency Drive
N/A	Not applicable

References

- [1] BOSCH, ICAT ISTANBUL 13/11/08 (Accessed 9th March 2019)
- [2] Ning Ding*, K. Prasad and T.T. Lie The electric vehicle: a review, International Journal of Electric and Hybrid Vehicles 9(1):49, pg. no. 5 (52) , January 2017 (Accessed 9th March 2019)
- [3] For all cars, EV Database and Authorized Website of a Brand (Accessed from 15th March till 4th May)
- [4] Electrical4u Exact Equivalent Circuit for Induction Motor. (Accessed: 19th March 2019)
- [5] chettinadtech.ac.in, Torque Vs. Speed characteristic of Induction Motor (Accessed: 15th May 2019)
- [6] V- Curve Synchronous Motor UNIT 7 SYNCHRONOUS MOTOR Structure (Accessed 26th March 2019)
- [7] PMSM Torque Equation, <https://www.mathworks.com/help> (Accessed 28th March 2019)
- [8] PMSM Torque Speed Characteristics. An Advanced Simulation Tool Based on Physical Modeling of Electric Drives in Automotive Applications (Thomas Bäuml, H. Giuliani, Dragan Simic, Franz Pirker). (Accessed 28th March 2019)
- [9] Torque Speed Characteristics of IM in all regions to explain Regenerative Breaking, Electrical4u (Accessed 29th March 2019)
- [10] PWM in an Electronic Control Drive, Yaskawa America (Accessed 30th March 2019)
- [11] Global Market % Share of Lithium Ion Battery manufacturers, Statista (Accessed 2nd April 2019)
- [12] Different Types of Batteries, Circuit Digest. (Accessed 4th April 2019)
- [13] Nickel Cadmium (NiCd) Cell, en.wikipedia.or (Accessed 4th April 2019)
- [14] Lead Acid Battery, <http://www.bhphotovideo.com> (Accessed 4th April 2019)
- [15] Lithium Ion Battery, <http://www.directindustry.com> (Accessed 4th April 2019)
- [16] Battery University for more details on 6 types of Lithium Ion Batteries along with their respective energy densities. Last updated: 2018-05-31 (Accessed 7th April 2019)
- [17] Periodictable.com (For Earth Crust Composition) (Accessed: 27th March 2019)
- [18] A Behind the Scenes Take on Lithium-ion Battery Prices BloombergNEF (Accessed: 21st July 2019)
- [19] Li-ion Cell Formats, EV Tech explained (22nd February 2019)
- [20] BMW Cell Module GREENTEC AUTO (25th February 2019)
- [21] Tesla Cell Module hackaday.io (25th February 2019)
- [22] Coolant Strategies of Different manufacturers along with their Battery Pack Details, JingWei Zhu (Accessed 5th March 2019)
- [23] Charging Facility Map Across Europe, Chargemap - charging stations for electric cars (Accessed 11th April 2019)
- [24] Different Types of Chargers Used for EVs, EV Charging Connector Types and Speeds | Pod Point (Accessed 11th April 2019)
- [25] Altitude and Longitude map between Prague and Brno, Mappy.cz (Accessed 28th April 2019)
- [26] Speed Assumption based on Instructions from Google Map for entire Track (Green to Red Indications on Track), (Accessed 28th April 2019)
- [27] Humidity, Air Pressure, Air Temperature, Average Wind Speed, www.yr.no Accessed 29th April 2019)
- [28] Air Density Online Calculator, engineersedge.com (Accessed 29th April 2019)
- [29] Aero Dynamic Drag Tesla Model 3, evworld.com (Accessed 29th April 2019)
- [30] Aero Dynamic Drag Nissan Leaf, (Accessed 30th April 2019)
- [31] Nissan Leaf Motor Efficiency, coilwindingexpo.com (Accessed 5th May 2019)
- [32] Tire size, tiresize.com (Accessed 7th May 2019)
- [33] Aerodynamic Drag VolksWagon e-Golf, adandp.media (Accessed 25th May 2019)
- [34] VolksWagon e-Golf Motor Efficiency, a-pointduurzaamheid.nl (Accessed 25th May 2019)

- [35] Tesla Model 3 Motor Efficiency, electrek.co (Accessed 26th May 2019)
- [36] Dry Electrode Coating Technology Hieu Duong, Joon Shin & Yudi Yudi Maxwell Technologies, Inc. 3888 Call Fortunada, San Diego, CA 92123 / 1-858-503-3296 (Accessed 12th April 2019)
- [37] Graphene Cells, All-graphene-battery: Bridging the gap between supercapacitors and lithium ion batteries by Haegyeom Kim, Kyu-Young Park, Jihyun Hong and Kisuk Kang (Accessed 14th April 2019)
- [38] Silicon-based nanomaterials for lithium-ion batteries by YIN YaXia, WAN LiJun & GUO YuGuo* (Accessed 15th April 2019)
- [39] SOLID ELECTROLYTE BATTERIES by John B. Goodenough and Yuhao Lu at Texas Materials Institute, The University of Texas at Austin (Accessed 17th April 2019)
- [40] Solid state Batteries ,Batteries for Electric Road Vehicles by John Goodenough (Ph.D. Physics), University of Texas at Austin (USA) and Maria Helena Braga (Ph.D. Physics), University of Porto (Portugal) (Accessed 19th April 2019)
- [41] Circuit Boost Using Ultra Capacitors, Maxwell Technologies (Accessed 20th April 2019)
- [42] Systems Architectures of HEVs, the State of the Art of Electric, Hybrid, and Fuel Cell Vehicles Publisher: IEEE, C. C. Chan (Accessed 21st April 2019)
- [43] Technical Specifications and Price KIA Optima, <https://www.kia.com/de/> (Accessed 22nd April 2019)
- [44] Technical Specifications and Price KIA Optima, <https://www.kia.com/fi/> (Accessed 22nd April 2019)
- [45] Technical Specifications KIA Optima, <https://www.kiamedia.com> (Accessed 22nd April 2019)
- [46] Technical Specifications Tesla Model 3, EV Database (Accessed 23rd April 2019)
- [47] Technical Specifications Tesla Model 3, <https://www.tesla.com/model3> (Accessed 23rd April 2019)
- [48] Total Number of Parts in EV and Fuel Vehicles, <https://skeptics.stackexchange.com/questions/40383/do-electric-cars-inherently-consist-of-fewer-parts-than-combustion-engine-cars> (Accessed 24th April 2019)
- [49] Maintenance cost Reference KIA OPTIOMA, <https://www.yourmechanic.com> (Accessed 12th May 2019)
- [50] Maintenance cost Reference TESLA MODEL 3, <https://cleantechnica.com> (Accessed 12th May 2019)
- [51] Price of Electricity in Czechia as per Statista, <https://www.statista.com> (Accessed 14th May 2019)
- [52] Price of Gasoline (Petrol) in Czechia as per Statista, <https://www.statista.com> (Accessed 14th May 2019)
- [53] Inflation rate (2%) in Czech Republic, <https://www.statista.com> (Accessed 14th May 2019)
- [54] Multi-Protocol Stations Could Resolve Fast Charging Standards War, <https://www.pluginCars.com> (Accessed 11th April 2019)
- [55] Intercalation Definition, Wikipedia, (Accessed 6th April 2019)
- [56] Fisker Emotion, <https://www.digitaltrends.com/cars/fisker-emotion-teaser-price/>, (Accessed 23rd April 2019)

Yearly Cost Analysis for KIA OPTIMA	32643.20	Kč
Yearly Cost Analysis for Tesla Model 3	12928.13	Kč
Minimum Expected Life of Car	10.00	Years
Percentage Escalation in Price of Gasoline/ Gallon in Czech Republic	0.07	%
Percentage Escalation in Price of Electricity/ kWh in Czech Republic	0.01	%
Inflation	0.020	2.00%
Yearly Maintenance cost KIA Optima	11581.70	Kč
Yearly Maintenance cost Tesla Model 3	14061.88	Kč

USD to Kč	22.65
Euro to Kč 2018	25.54
KIA Optima Price in USA	35390 USD
Tesla Model 3 in Germany	54800 Euro
KIA Optima Price in Germany	42190 Euro

Driving Cost for life KIA Optima

AD	2019	2020	2021	2022	2023	2024	2025	2026	2027	2028	2029	TOTAL COST
Years of Service	0	1	2	3	4	5	6	7	8	9	10	
Capital Investment	1077532.60	0.00	0.00	0.00	0.00	0.00	0.00	0.00	0.00	0.00	0.00	1077532.60 Kč
Fuel Cost	32643.20	35581.08	38026.06	40642.18	43441.44	46436.64	49641.50	53070.70	56739.95	60666.05	64866.97	521755.77 Kč
Maintenance (Cumulative Inflation)	0.00	11813.33	12049.60	12290.59	12536.40	12787.13	13042.88	13303.73	13569.81	13841.20	14118.03	129352.71 Kč

Driving Cost for life Tesla Model 3												
AD	2019	2020	2021	2022	2023	2024	2025	2026	2027	2028	2029	TOTAL COST
Years of Service	0	1	2	3	4	5	6	7	8	9	10	
Capital Investment	1399592.00	0.00	0.00	0.00	0.00	0.00	0.00	0.00	0.00	0.00	0.00	1399592.00 Kč
Charging Cost	12928.13	13303.04	13420.44	13538.90	13658.42	13779.02	13900.71	14023.49	14147.37	14272.37	14398.49	151370.40 Kč
Maintenance (Cumulative Inflation)	0.00	14343.11	14629.97	14922.57	15221.03	15525.45	15835.96	16152.67	16475.73	16805.24	17141.35	157053.08 Kč

Total Cost Difference After 10 years of Driving Tesla as opposed to KIA Optima	
Price Difference Between KIA Optima and Tesla Model 3	322059.40 Kč
Fuel Cost Difference Between KIA Optima and Tesla Model 3	-370385.38 Kč
Maintenance Cost Difference Between KIA Optima and Tesla Model 3	27700.37 Kč

To find out Price Difference Compensation Period	
KIA Optima	Difference
Tesla Model 3	342685.01

CONCLUSION

Thus for an individual Price Difference between cars can be paid back by 10 years of driving Tesla Model 3 based on above assumptions

Driving Cost for life Tesla Model 3												
AD	2019	2020	2021	2022	2023	2024	2025	2026	2027	2028	2029	TOTAL COST
Years of Service	0	1	2	3	4	5	6	7	8	9	10	
Capital Investment	41450.00	0.00	0.00	0.00	0.00	0.00	0.00	0.00	0.00	0.00	0.00	41450.00
Charging Cost	340.46	350.13	351.50	352.87	354.25	355.64	357.03	358.42	359.82	361.23	362.64	3903.99
Maintenance (Cumulative Inflation)	0.00	593.30	607.77	622.60	637.80	653.36	669.30	685.63	702.36	719.50	737.05	6628.68

Total cost Difference After 10 years of Driving Tesla as opposed to KIA Optima

Price Difference Between KIA Optima and Tesla Model 3	6060.00	\$
Fuel Cost Difference Between KIA Optima and Tesla Model 3	-6961.10	\$
Maintenance Cost Difference Between KIA Optima and Tesla Model 3	776.37	\$

To find out Price Difference Compensation Period

KIA Optima	16717.40	Difference
Tesla Model 3	10532.67	6184.73

CONCLUSION

Thus for an Individual Price Difference between cars can be paid back by 10 years of driving Tesla Model 3 based on above assumptions

Appendix-3 EV Performance Analysis (Top Speed 90)

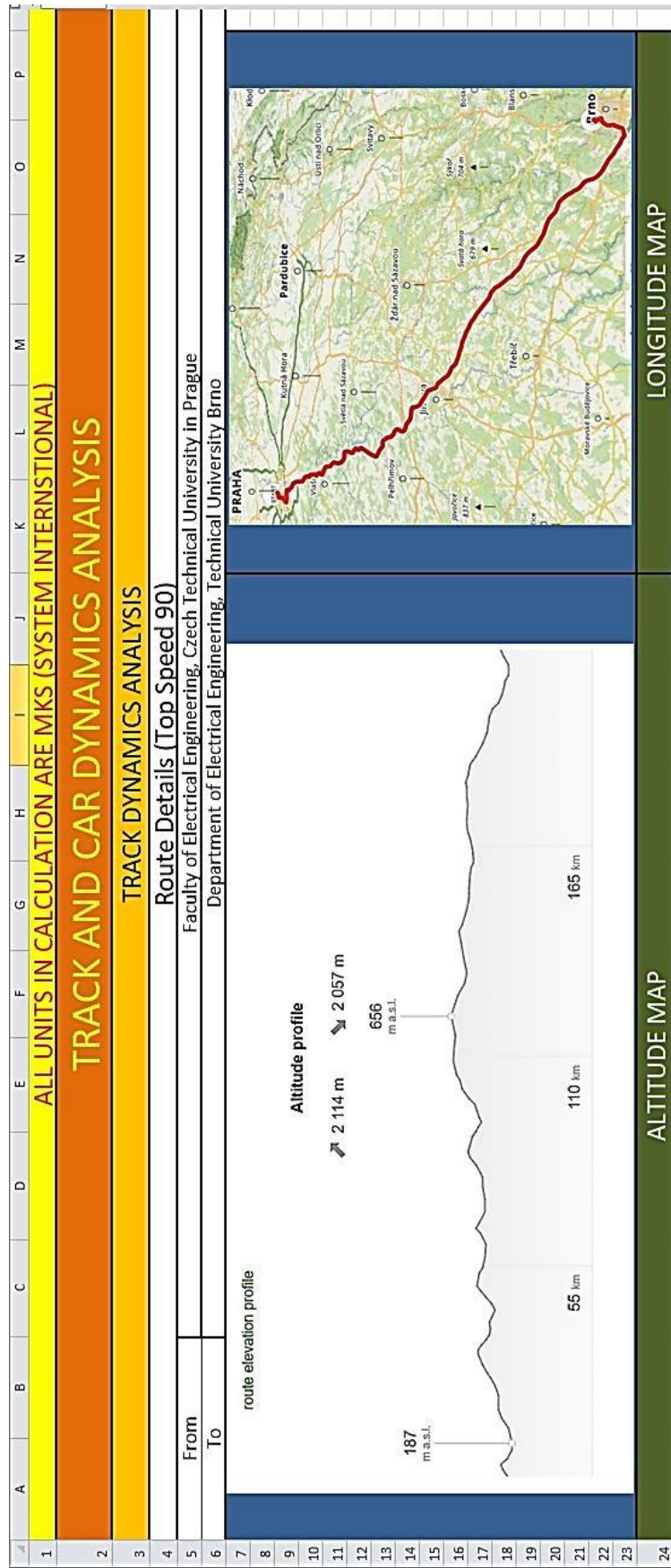

	A	B	C	D	E	F	G	H	I	J	K	L	M	N	O	P
26		Total Distance (Actual Longitude, Calculated from Hypotenuse)	215378.575	215.3785747	km											
27		Segment Number	1	2	3	4	5	6	7	8	9	10	11	12	13	14
28		Covered Horizontal Distance in Segments (km)	0.000	1.899	3.798	5.697	7.596	9.495	11.394	13.293	15.192	17.091	18.990	20.889	22.788	24.687
29		Covered Horizontal Distance in Segments (m)	0.000	1899.000	3798.000	5697.000	7596.000	9495.000	11394.000	13293.000	15192.000	17091.000	18990.000	20889.000	22788.000	24687.000
30		Longitudinal Difference Between 2 Points (m)	1899.000	1899.000	1899.000	1899.000	1899.000	1899.000	1899.000	1899.000	1899.000	1899.000	1899.000	1899.000	1899.000	1899.000
31		Meters above Sea Level (meters)	216.000	261.000	342.000	198.000	205.000	187.000	217.000	285.000	313.000	297.000	275.000	327.000	342.000	275.000
32		Altitude Difference Between 2 Points (m)	45.000	81.000	-144.000	7.000	-18.000	30.000	68.000	28.000	-16.000	-22.000	52.000	15.000	-67.000	108.000
33		Square of Longitude (m^2)	3606201.00	3606201.00	3606201.00	3606201.00	3606201.00	3606201.00	3606201.00	3606201.00	3606201.00	3606201.00	3606201.00	3606201.00	3606201.00	3606201.00
34		Square of Altitude (m^2)	2025.00	6561.00	20736.00	49.00	324.00	900.00	4624.00	784.00	256.00	484.00	2704.00	225.00	4489.00	11664.00
35		Hypotenuse (m)	1899.53	1900.73	1904.45	1899.01	1899.09	1899.24	1900.22	1899.21	1899.07	1899.13	1899.71	1899.06	1900.18	1902.07
36		(Sinθ in Radian)	0.024	0.043	-0.076	0.004	-0.009	0.016	0.036	0.015	-0.008	-0.012	0.027	0.008	-0.035	0.057
37		Cosθ	1.000	0.999	0.997	1.000	1.000	1.000	0.999	1.000	1.000	1.000	1.000	1.000	0.999	0.998
38		Vehicle Longitudinal Speed V (km/h)	0.000	35.000	90.000	90.000	90.000	90.000	90.000	90.000	90.000	90.000	90.000	90.000	90.000	90.000
39		Vehicle Longitudinal Speed V (m/s)	0.000	9.722	25.000	25.000	25.000	25.000	25.000	25.000	25.000	25.000	25.000	25.000	25.000	25.000
40		Time To Cover Distance in Intervals (Seconds)	0.000	195.503	76.178	75.961	75.963	75.969	76.009	75.968	75.963	75.965	75.988	75.962	76.007	76.083
41		Cummulative Time To Cover Distance (Seconds)	0.000	195.503	271.681	347.642	423.605	499.575	575.583	651.552	727.514	803.480	879.468	955.430	1031.438	1107.520
42		Location	CVUT	Presni Most	D1 Highway	D1 Highway	D1 Highway	D1 Highway	D1 Highway	D1 Highway	D1 Highway	D1 Highway	D1 Highway	D1 Highway	D1 Highway	D1 Highway
43		Nissan Leaf (RPS aka Cycles per second)	0.000	30.718	78.989	78.989	78.989	78.989	78.989	78.989	78.989	78.989	78.989	78.989	78.989	78.989
44		Tesla Model 3 (RPS aka Cycles per second)	0.000	29.108	74.850	74.850	74.850	74.850	74.850	74.850	74.850	74.850	74.850	74.850	74.850	74.850
45																

	A	B	C	D	E	F	G	H	I	J	K	L	M	N	O	P
45																
46			FIXED QUANTITIES													
47			Height from Sea Level	216	meter								Conversion from km/h to m/s	0-100 km/h =	0-27.78 m/s	27.778
48			Gravitational Acceleration	9.8	m / s ²								Nissan Leaf			
49			Average Humidity	63%									Acceleration			
50			Average Air Pressure	1.024	Bar								Standard Acceleration 0-100 Time (Seconds)	7.3	Second	
51			Air Density (p)	0.444	kg / m ³								Standard Acceleration (m/s ²)	(v2-v1)/t	3.81	m/s ² in 7.3s
52			Air Temperature	19	°C								Speed Span (km/h)	0-35	35-60	
53			Total Time for both Cars to cover Distance	8970.91	Seconds	Hours							Speed Span (m/s)	0-9.7	9.7-33.33	9.7-16.67
54			Average Wind Speed (Vw)	5	km / h	1.39	m/s						Acceleration (m/s ²)	3.81	3.81	m/s ²
55													Time (s)	2.555	6.205	1.825
56																
57			Mechanical Specs of Cars													
58			Mass of Vehicle	Co-efficient of Rolling Resistance	Aerodynamic Drag	Height	Width	Frontal Area	Radius of Wheel + Tire (rd)							
59			m (kg)	Crr	Cx	a (m)	b (m)	A (m ²)	m							
60		Nissan Leaf e+	1731	0.015	0.28	1.50	1.80	2.70	0.32							
61		Tesla Model 3	1847	0.015	0.13	1.40	1.9	2.66	0.33							
62																

	A	B	C	D	E	F	G	H	I	J	K	L	M	N	O	P
63																
64	ENERGY CALCULATION WHILE PHASES															
65	TOTAL ENERGY CONSUMED WHILE ACCELERATION PHASE															
66					$E_{acc} = E_{roll} + E_{rise} + E_m + E_{aero}$			Nissan Leaf	Eacc	788316.303	(Joule)					
67								Tesla Model 3	Eacc	798163.103	(Joule)					
68																
69																
70					Energy Consumed Due to Gravity while climbing up (Erise) (Joule)											
71					Nissan Leaf e+	4991.318	50390.835	1321.343								
72					Tesla Model 3	2940.091	29682.273	778.325								
73																
74					Energy Consumed Due to Rolling Resistance (Eroll) (Joule)											
75					Nissan Leaf e+	3159.504	17720.777	6127.257								
76					Tesla Model 3	1985.795	11137.768	3851.071								
77																
78					Energy Consumed Due to Aero Dynamic Drag (Eaero) (Joule)											
79					Nissan Leaf e+	98.515	4208.736	752.300								
80					Tesla Model 3	26.543	1133.967	202.694								
81																
82					Energy Consumed in Overcoming Inertia of Car (Ein) (Joule)											
83					Nissan Leaf e+	81808.4	459129.1	158608.2								
84					Tesla Model 3	87290.7	489896.8	169237.1								
85																
86					Total Energy Consumed While Acceleration (Eacc) (Joule)											
87					Nissan Leaf e+	90057.786	531449.398	166809.118								
88					Tesla Model 3	92243.132	531850.806	174069.166								
89																
90																

	B	C	D	E	F	G	H	I	J	K	L	M	N	O
91	TOTAL ENERGY CONSUMED WHILE CONSTANT SPEED PHASE													
92	Econ = Eroll + Erise + Eaero													
93	Econ													
94	Econ													
95	NOTE: Calculation for only the part of track where are run at constant Speed													
96	Leaf et	763850.6766	1376760.801	-2435810.762	118751.128	-305372.783	509176.6957	1152924.861	474951.6338	-271429.3795	-378318.4402	881814.579	254607.3821	-1137703.314
97	Model 3	815038.8213	1469022.068	-2599042.448	126709.031	-325836.817	543298.2358	1230186.145	506779.7041	-289618.7544	-398335.736	940907.873	271669.4597	-1213944.553
98														
99	Energy Consumed Due to Rolling Resistance (Eroll) (Joule)													
100	Leaf et	483517.4783	484160.8817	481833.8163	483232.267	483252.4286	483463.2156	482956.8332	483178.4746	483229.1171	483362.5349	483047.852	483499.4187	483693.7151
101	Model 3	515919.5739	516606.0938	514123.0842	515615.249	515636.7624	515861.6749	515321.3581	515557.8525	515611.8887	515754.2472	515418.476	515900.3041	516107.6209
102														
103	Energy Consumed Due to Aero Dynamic Drag (Eaero) (Joule)													
104	Leaf et	30152.653	199767.481	199196.958	199204.553	199220.460	199323.272	199217.257	199202.675	199208.972	199270.271	199201.819	199319.546	199517.487
105	Model 3	13792.047	91375.126	91114.164	91117.638	91124.914	91171.941	91123.449	91116.779	91119.659	91147.698	91116.388	91170.237	91260.776
106														
107	Total Energy Consumed While Constant Speed (Econ) (Joule)													
108	Leaf et	1277520.808	2060689.164	-1754779.987	801187.947	377100.106	1191963.123	1835098.951	1157332.784	411008.710	309314.366	1564064.25	937426.347	-454492.112
109	Model 3	1344750.442	2077003.287	-1993805.199	733441.919	280924.860	1150331.852	1836630.953	1113454.336	317112.794	208566.209	1547442.74	878740.000	-606576.156
110														
111														
112														

	A	B	C	D	E	F	G	H	I	J	K	L	M	N	O	
142	FINAL EFFICIENCY AND ENERGY CALCULATION															
143	ASSUMPTIONS AND SPECIFICATIONS															
144	N LEAF	TESLA MODEL 3														
145	97%	$\eta_{\text{drivetrain}}$	Assumed													
146	96%	$\eta_{\text{bat_char}}$	Assumed													
147	94%	$\eta_{\text{bat_dischar}}$	Assumed													
148	93%	η_{motor}	Sourced Data													
149	91%	$\eta_{\text{converter}}$	Assumed													
150	Driving Efficiency	70.00%		This stands for assumption that amount of energy lost due to traffic and other inside utilities of car (i.e. Electronics in the car). Here remainder is the loss and the percentage shows the energy that could be used.												
151																
152																
153	Electrical Specs of Cars															
154		Rated Battery Capacity	Battery Capacity	Rated Motor Torque	Rated Motor Power	Top Speed	Top Speed	Rated RPS of Driven Gear (CONSIDERED)	Gear Ratio	Rated RPS of Driver Gear (ADDITIONAL CALCULATION)						
155		Wh	Ws	Nm	Watt	km/h	m/s	1/s		1/s						
156	Leaf et	62000	228200000	340	160000	193.12	53.64	169.49	2.94	497.80						
157	Model 3	75000	270000000	527	258000	233	64.72	193.78	9	1744.01						
158																

	A	B	C	D	E	F	G	H	I	J	K	L	M	N	O
158															
159	Nissan Leaf Efficiency Based Energy Calculation														
160	Efficiency = (Output/ Input)*100%														
	Nissan Leaf Energy in Acceleration Phase			Input Power of Battery Pack to the System of Car and then Finally to The Road			Understanding the logic for these equations								
	Enacc (Nissan Leaf)	1459414.11	Watt												
162															
163	Nissan Leaf Energy in Constant Speed Phase			Input Power of Battery Pack to the System of Car and then Finally to The Road			We know Power Output of the car from Energy Calculation. But, we need to find out Power Input of the car with regards to Efficiency and for this I have implemented logic as mentioned on the left								
164	Encon (Nissan Leaf)	142494974.82	Watt												
165															
166	Nissan Leaf Energy in DECELERATION PHASE			Output Power of The System of Car to the Battery Pack											
167	Endecel (Nissan Leaf)	-398851.57	Watt												
168															
169	Nissan Leaf Power Statistic														
170	Eoverall (Nissan Leaf)	14355537.36	Watt*s	39876.54	Wh	39.88	kWh	ENERGY CONSUMED							
171	Power remaining in Nissan Leaf Battery Bank after Ride	22123.46	Wh	22.12	kWh	CONCLUSION: Nissan Leaf can make it from CVUT/ Prague To Technical University Brno in single charge in given Ambient condit									
172															
173															

	A	B	C	D	E	F	G	H	I	J	K	L	M	N	O
173															
174	Tesla Model 3 Efficiency Based Energy Calculation														
175	Efficiency = (Output/ Input)*100%														
176	Enacc (Tesla Model 3)	1385628.51	Watt		Input=Output/ Effi.		Input Power of Battery Pack to the System of Car and then Finally to The Road		Understanding the logic for these equations						
177															
178	Encon (Tesla Model 3)	119682131.78	Watt		Input=Output/ Effi.		Input Power of Battery Pack to the System of Car and then Finally to The Road		We know Power Output of the car from Energy Calculation. But, we need to find out Power Input of the car with regards to Efficiency and for this I have implemented logic as mentioned on the left						
179															
180															
181	Endecel (Tesla Model 3)	-536228.46	Watt		Output=Input*Effi.		Output Power of The System of Car to the Battery Pack								
182															
183															
184	Tesla Model 3 Power Statistic														
185	Overall (Tesla Model 3)	120531531.83	Watt*s	33480.98	Wh	33.48	kWh	ENERGY CONSUMED							
186	Power remaining in Tesla Model 3 Battery Bank after Ride	41519.02	Wh	41.52	kWh	CONCLUSION: (Tesla Model 3) can make it from CVUT/ Pra To Technical University Brno in single charge in given Ambient co									
187	NOTE: AS YOU CAN SEE IN DATA, I HAVE CONSIDERED LEAST TRAFFIC CONDITION. THUS ENERGY CONSUMPTION IS LEAST														
188															